

EU SCAN 1006 HE +

EU - ASSEMBLY AND INSTRUCTIONS MANUAL

SCAN 1006 HE +



ASSEMBLY AND INSTRUCTION MANUAL SCAN 1006 HE +

EU SCAN 1006 HE +

# CONGRATULATIONS ON YOUR NEW SCAN BUILT-IN STOVE

You have purchased a product by one of Europe's leading manufacturers of wood-burning stoves, and we are sure that you will have years of pleasure from your purchase.

To make the best possible use of your stove, it is important that you follow our advice and instructions. Read through this Assembly and Instruction Manual carefully before you start to assemble your stove.

SCAN 1006



# CONTENTS

<b>TECHNICAL DATA</b>	<b>4</b>		
Installation	4	Product registration number	7
Safety	4	Dimension sketch	8
Technical data	5	Minimum distances	9
Type plate	7		
<b>ASSEMBLY</b>	<b>10</b>		
Tools needed for mounting of the insert	10	Remove packaging	13
Loose parts	10	Fitting the flue connection piece	15
Additional accessories	10	Fresh air intake	15
Disposal of packaging	10	Closed combustion system	15
Room requirements	11	Mounting of external air supply	16
Load-bearing foundation	11	Fitting without the convection connection pieces	18
Floor plate	11	Fitting the convection connection pieces	18
Existing chimney and pre-fabricated element chimney	11	Fitting the cassette	19
Connection between built-in stove and steel chimney	11	Mount the insert in the cassette	22
Requirements for chimney	11	Mounting of the trim	23
Trims and doors	12	Mounting of convection grate	24
Gasket	12	Mounting of catalyst	25
Internal installation in non-flammable material	12	Mounting of combustion chamber	26
Safety distance	12	Adjustment of the door	28
Operating the door	13	Door (Self-closing)	28
<b>INSTRUCTIONS FOR USE</b>	<b>29</b>		
CB-technology (Clean Burn)	29	Primary air	29
Baffle plate	29	Secondary air	29
<b>IINSTRUCTIONS FOR HEATING</b>	<b>30</b>		
Environmentally-friendly firing	30	Firing in the spring or autumn	31
Lighting	30	General notes	31
Continuous operation	31	The function of the chimney	32
Warning about over-firing	31	Chimney fire	32
Using the stove in various weather conditions	31		
<b>HANDLING OF THE FUEL</b>	<b>33</b>		
Selecting wood/fuel	33	Moisture	33
Preparation	33	Use of the following as fuel is illegal	33
Storing	33	Calorific value of the wood	33
<b>MAINTAINANCE</b>	<b>34</b>		
<b>TROUBLESHOOTING</b>	<b>36</b>		
<b>WARRANTY</b>	<b>37</b>		

# TECHNICAL DATA

## INSTALLATION

---

- All local regulations, including those referring to national and European Standards as well as the information provided in this assembly and instruction manual need to be complied with when installing the appliance
- When you install any kind of fireplace or stove, you must inform the local building and housing authorities. In addition you are obliged to have the installation inspected and approved by a local chimney sweep prior to commissioning
- To ensure best-possible functionality and safety for your installation, we advise you to call a professional fitter. Your Scan Dealer will be able to recommend a qualified fitter in your area. For information on Scan Dealers, please go to [www.scan-stoves.com](http://www.scan-stoves.com)

## SAFETY

---

Any changes made to the product by the dealer, fitter or user could result in the product and safety functions not functioning as intended. The same applies to the fitting of accessories or extra equipment not supplied by Scan A/S. This could also be the case if parts that are necessary for the operation and safety of the stove are dismantled or removed.



### ■ PLEASE NOTE!

YOU GET THE BEST USE OF  
THE STOVE BY USING  
A TOP-DOWN  
LIGHTING METHOD

SEE  
"INSTRUCTIONS FOR HEATING"



## TECHNICAL DATA

Test in compliance with EN 16510*		
	Classification of appliance	Type BE
$P_{nom}$	Nominal heat output	8.2 kW
$\eta_{nom}$	Energy efficiency at nominal heat output	85 % (85.5)
$\eta_{s nom}$	Seasonal space heating energy efficiency at nominal heat output	75 %
EEl	Energy efficiency index	113
	Energy efficiency class	A+
	Fuel	Wood**
	Fuel length, maximum	650 mm
	Fuel consumption	2.3 kg/h
	Amount of fuel	1.7 kg
	Amount of fuel, maximum	2.5 kg
$CO_{nom}$	CO emission at 13% O <sub>2</sub> at nominal heat output	0.032 % 380 mg/Nm <sup>3</sup>
$NO_{x nom}$	NO <sub>x</sub> emission at 13% O <sub>2</sub> at nominal heat output	100 mg/Nm <sup>3</sup>
$OGC_{nom}$	OGC emission at 13% O <sub>2</sub> at nominal heat output	32 mg/Nm <sup>3</sup>
$PM_{nom}$	Dust emission at 13% O <sub>2</sub> at nominal heat output	24 mg/Nm <sup>3</sup>
$p_{nom}$	Flue draught at nominal heat output	12 Pa
	Recommended sub-pressure in the connecting piece	20-22 Pa
	Required combustion air supply	24.4 m <sup>3</sup> /h
$T_{fg nom}$	Flue gas temperature at nominal heat output	176 °C
$T_{s nom}$	Temperature in the flue connecting piece at nominal heat output	211 °C
T class	Chimney designation	T400 G
$\emptyset_{f.g nom}$	Flue gas mass flow at nominal heat output	8.5 g/sec
$V_h$	Standing air loss	0 m <sup>3</sup> /h
CON/INT	Continuous operation (CON)/Intermittent operation (INT)	INT***
	Reaction to fire classification	A1

\* EN 16510 was carried out on the installation shown on page 9.

\*\* Use only recommended fuels - designation I.

\*\*\* Intermittent operation in this context means normal use of a wood-burning stove. In other words, you should let the fire die down until only the embers are left before refueling.

## TECHNICAL DATA

### Basic technical data

Materials	Stainless steel Galvanised sheet Ceramic stone Chamotte Robax glass
Surface treatment	Senotherm
$d_{out1}$	Connecting piece int. diameter for outside flue pipe 144 mm
$d_{out2}$	Connecting piece ext. diameter for outside flue pipe 148 mm
	Fresh air connection piece external diameter 100 mm
L	Overall dimensions (length) 438 mm
H	Overall dimensions (height) 470 mm
W	Overall dimensions (width) 800 mm
m	Mass (weight) 132 kg
$m_{chim}$	Maximum load of a chimney the stove may carry 200 kg
s	Protective insulation: fire wall (Calcium silicate boards) 50 mm
	Area for ingoing convection air 350 cm <sup>2</sup>
	Area for outgoing convection air 500 cm <sup>2</sup>

### Minimum distances to combustibile materials

$d_R$	Back	225 mm
$d_S$	Front to sides	500 mm
$d_{S1}$	Stoveside to sides	125 mm
$d_C$	Ceiling	1010 mm
$d_P$	Front	1500 mm
$d_F$	Front to the bottom front radiation area	0 mm
$d_L$	Front to the side front radiation area	0 mm
$d_B$	Below the bottom (not regarding feet)	0 mm
$d_{B1}$	Bottom edge of door to floor	465 mm
$d_{non}$	Minimum distances to non-combustible walls	10 mm

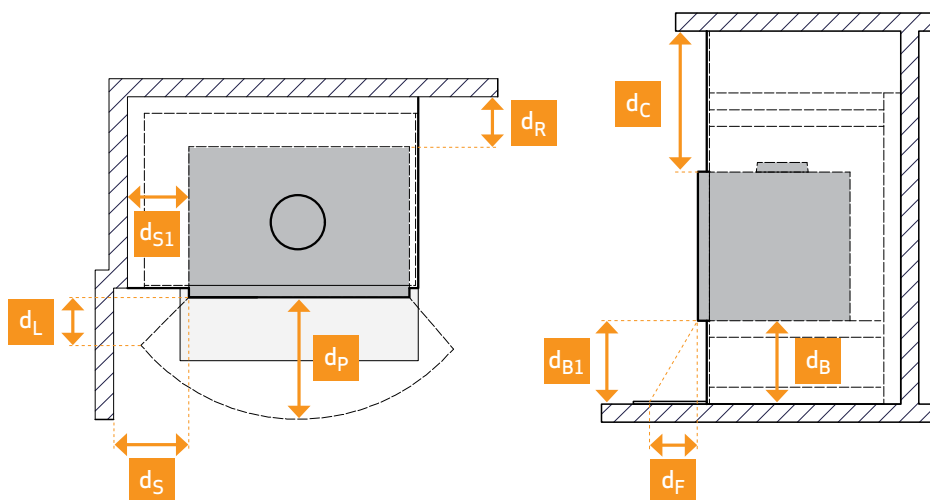

 This stove is produced in accordance with type approval for the product, which also covers the product's Assembly and Instruction Manual. Read and follow the user operating instructions carefully.

The Declaration of Performance (DoP) is available from [www.scan-stoves.com](http://www.scan-stoves.com).

## TYPE PLATE

All Scan wood-burning stoves are fitted with a type plate that specifies the approval standards and the distance to flammable materials.

The type plate for Scan 1006 HE + must be stuck on top of the existing type plate.

Type plate

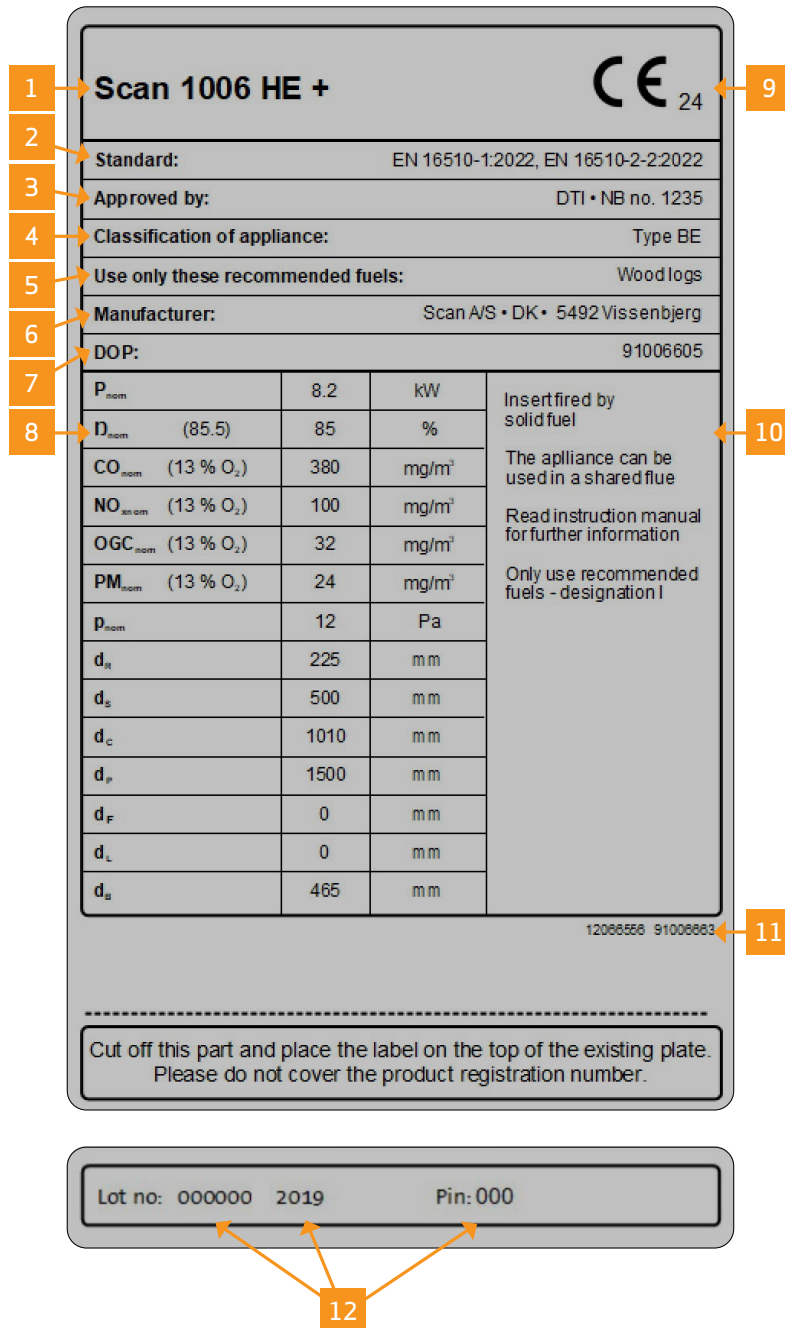

## TYPE PLATE EXPLANATION

- 1 Type and/or the model number or designation to enable the appliance to be identified
- 2 Applicable standards
- 3 Name of test centre/certification number
- 4 Classification of appliance
- 5 Recommended fuels
- 6 Manufacturer's name and address
- 7 DOP document number
- 8 Table of values:

$P_{nom}$  - nominal heat output

$\eta_{nom}$  - energy efficiency at nominal heat output

$CO_{nom}$  - CO emission at 13 % O<sub>2</sub> at nominal heat output

$NO_{xnom}$  - NO<sub>x</sub> emission at 13 % O<sub>2</sub> at nominal heat output

$OGC_{nom}$  - OGC emission at 13 % O<sub>2</sub> at nominal heat output

$PM_{nom}$  - dust emission at 13 % O<sub>2</sub> at nominal heat output

$p_{nom}$  - flue draught at nominal heat output

**Minimum distances to combustible material:**

$d_R$  - back

$d_S$  - sides

$d_C$  - ceiling

$d_P$  - front

$d_F$  - front to the bottom front radiation area

$d_L$  - front to the side front radiation area

$d_B$  - below the bottom (not regarding feet)

- 9 CE mark of conformity - The digits indicate the year of issue of the certificate
- 10 Product specifications and instructions
- 11 Type plate number
- 12 Product registration number

## PRODUCT REGISTRATION NUMBER

All Scan wood-burning stoves are provided with a product registration number. Please make a note of this number at the rear page of this manual; you will always need to quote it when contacting your dealer or Scan A/S.

# DIMENSION SKETCH

- A** Top outlet
- B** Rear outlet
- C** Centre external air supply, rear side
- D** Centre of external air supply, bottom

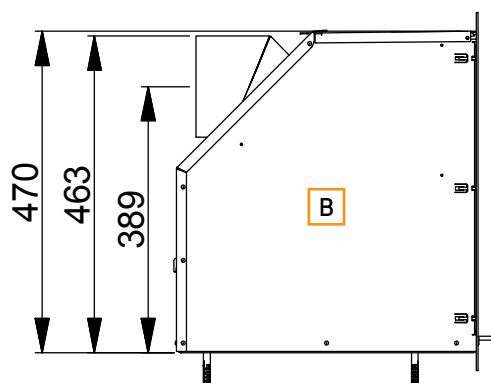
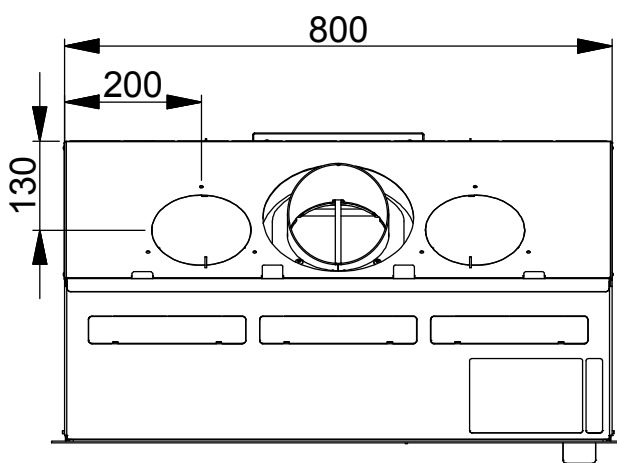
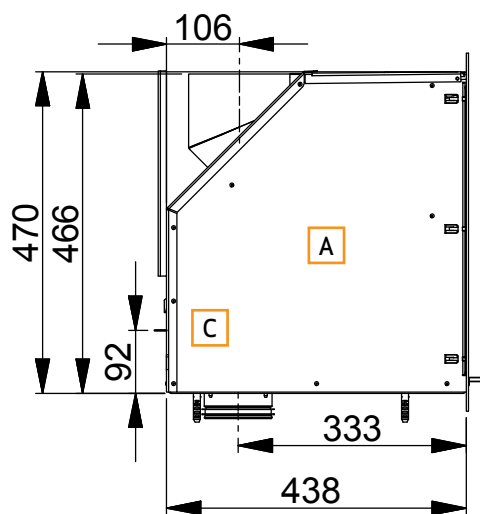
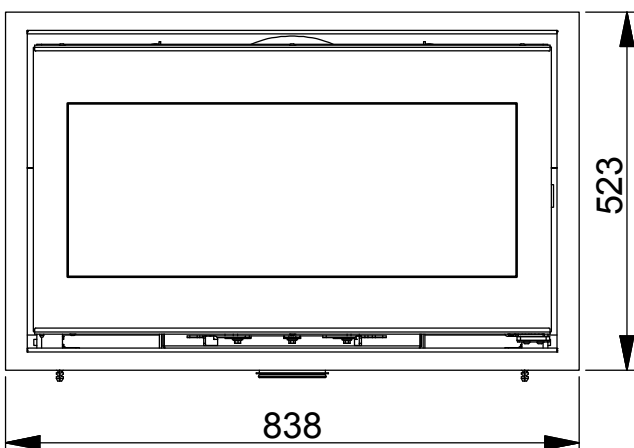
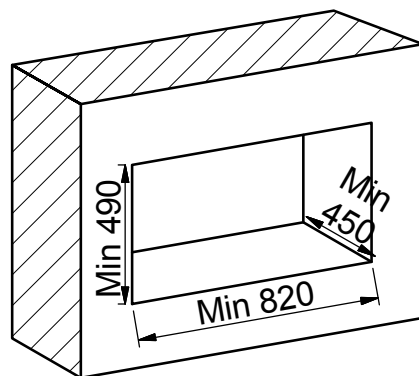
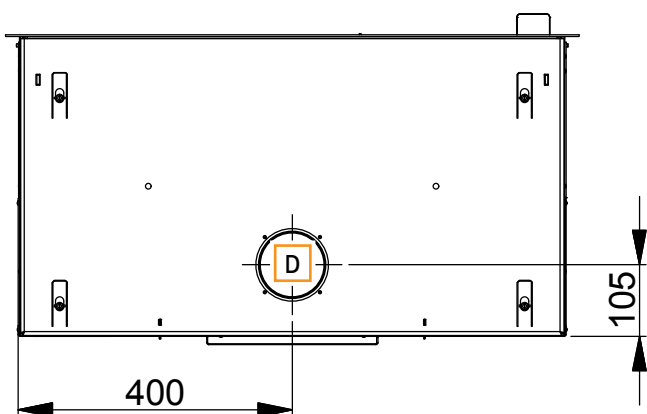

All measures are in mm





# MINIMUM DISTANCES

## Installation with an un-insulated elbow pipe

-  Flammable material
-  Fire wall, e.g. 50 mm Jøtul Firewall, 110 mm brick or other material with corresponding fireproof and insulating abilities
-  Chimney

All distances are in mm.

All distances are minimum distances

\* Applies for all installations

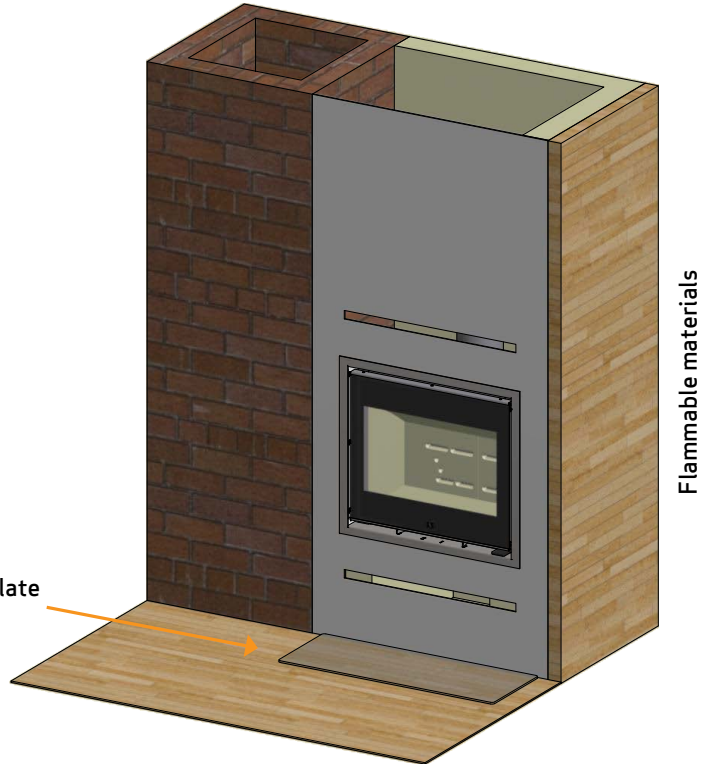

These cover plates must be removed when installing into flammable material protected by insulation

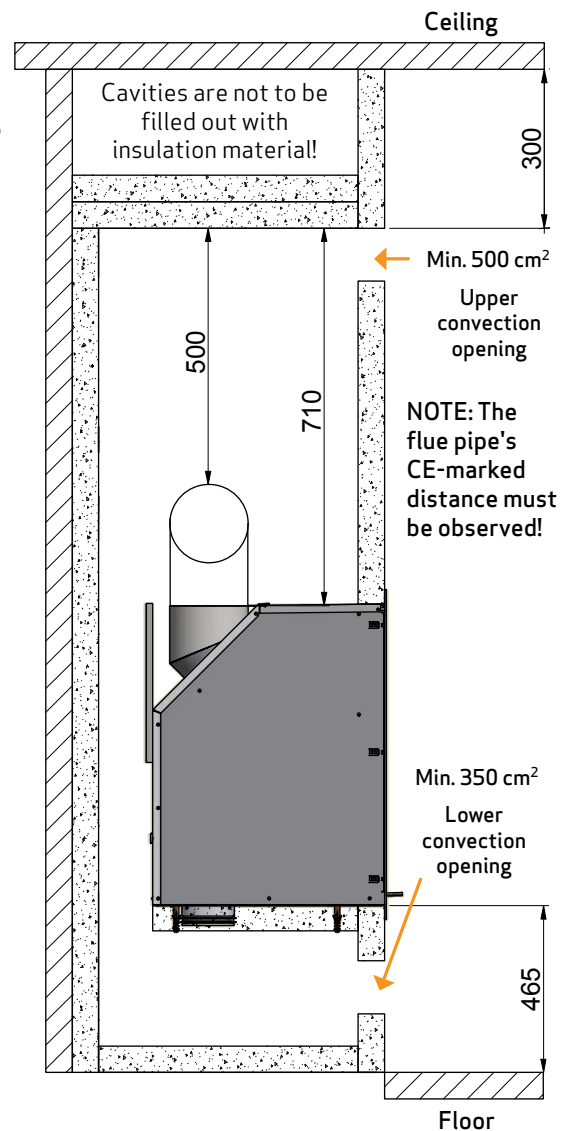
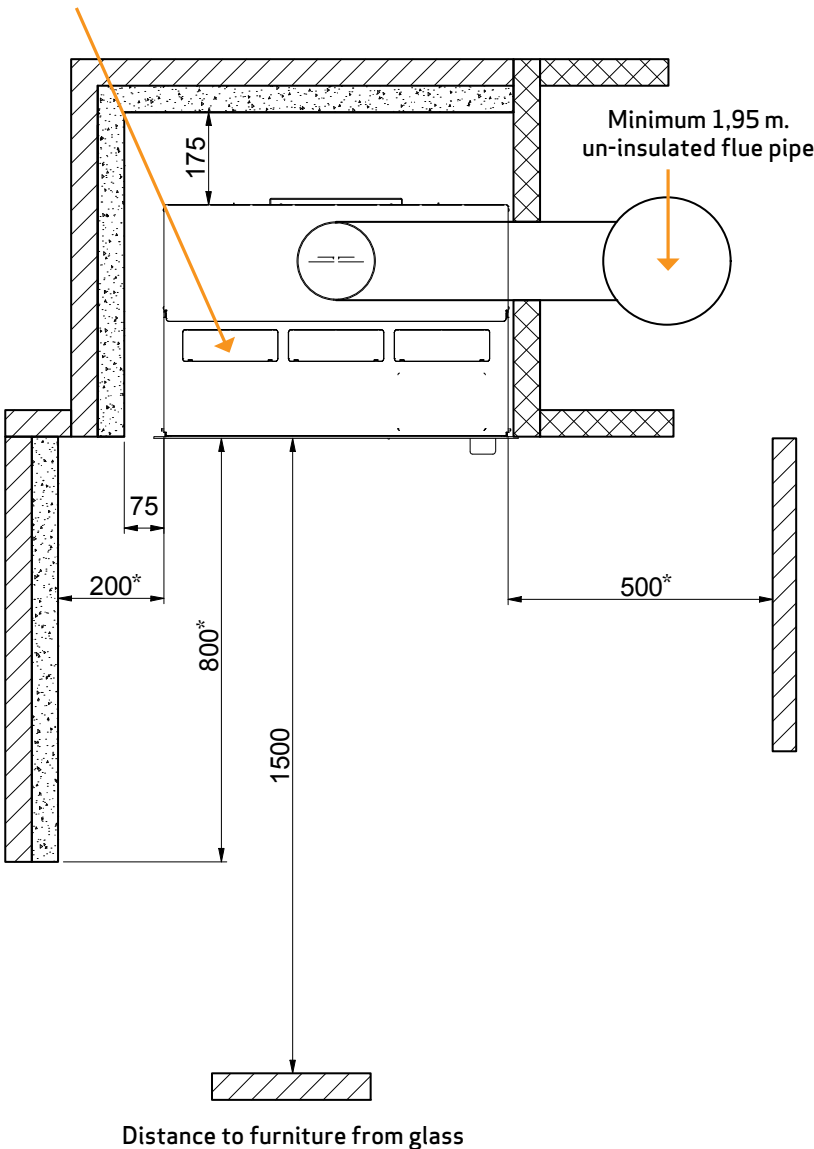

# ASSEMBLY

## TOOLS NEEDED FOR MOUNTING OF THE INSERT

---

- Spirit level
- Cross tip screwdriver
- Ø10 wall drill
- Cutting nippers
- Flat head screwdriver
- Open-end spanner

## LOOSE PARTS

---

The trim is packed separately.

In the insert's combustion chamber you will find the following loose parts:

- Bricks for the bottom of the burn chamber
- Baffle plate in steel  
(Must only be used on Scan 1006/Scan 1006 HE)
- Glove
- Bag containing loose parts:
  - 4 x self-tapping screws 4.2 x 6.5 mm  
(for fastening the sleeve Ø100 mm)
  - 4 x rawlplugs 10 x 50 mm (for fastening the cassette)
  - 4 x discs Ø6.5 / Ø16 x 1.1 (for fastening the cassette)
  - Ø100 mm sleeve with flange
- Log guard
- Folder with labels for Scan 1006 CS  
(Use folder for Scan 1006 HE + instead)
- 3 pins Ø6 x 40 mm (for baffle plates)
- 8 x 3 mm black self-adhesive gasket (2 m)  
(Ø100 mm sleeve, connecting piece and cassette)
- 4 x torx screws M6 x 50 (for fastening the cassette)
- Torx key T30
- 2 x screws M5x6 mm (Only used in Norway)

Combustion chamber package contains:

- Baffle plates
- Burn chamber plates (side and rear)

Flue pipe package contains:

- 2 x flue pipe 1000 mm (Ø150 mm)

Catalyst package contains:

- Box for catalyst
- Locking shaft
- Catalyst

Folder for Scan 1006 HE + contains:

- Energy label
- Type plate

## ADDITIONAL ACCESSORIES

---

- Convection adaptors Ø149 mm (see page 18)
- Convection grates (See page 24)

## DISPOSAL OF PACKAGING

---

Your Scan built-in stove may come supplied with the following packaging:

Wood packaging	The wood packaging can be reused and after final use can be incinerated as a CO <sub>2</sub> neutral product or sent for recycling.
Foam	Send for recycling or waste disposal
Plastic bags	Send for recycling or waste disposal
Stretch/plastic film	Send for recycling or waste disposal

## ROOM REQUIREMENTS

---

The stove must be installed in rooms with a good ventilation. A good ventilation is vital for the efficient operation of your stove. We recommend installing smoke detectors in the home.

The distances specified in the manual only apply if you comply with the maximum amount of firewood. They only guarantee fire safety.

You should however assess whether furniture or other items might become excessively dry due to being too close to the stove. There is no guarantee that the present building materials can withstand the temperature in relation to visual changes.

- The stove is NOT to be built into flammable materials without the use of a fire wall!
- Check that Building Regulations and any local by laws are followed during installation

## LOAD-BEARING FOUNDATION

---

All items in our product range come under the category of lightweight fireplaces and stoves and do not normally require any reinforcement of the beam structure. They can be positioned on ordinary beams/floor.

You should of course make sure that the foundation on which the stove is positioned can indeed support the weight of the stove and, where applicable, a steel chimney, if you have opted for this solution. In case of doubt about the carrying capacity of the floor, please consult a building expert.

## FLOOR PLATE

---

If you are placing the stove on a flammable floor, you must comply with the national and local regulations on the size of any non-flammable subsurface required to cover the floor around the stove.

Your local Scan dealer can advise you on regulations concerning protection of flammable materials in the vicinity of your stove.

The floor plate's function is to protect the floor and flammable material against any sparks that may occur.

## EXISTING CHIMNEY AND PRE-FABRICATED ELEMENT CHIMNEY

---

If you intend to connect your stove to an existing chimney, it makes sense to contact an authorised Scan dealer, or a local chimney sweep, for advice. These experts will also let you know if your chimney needs renovating.

- When connecting a pre-fabricated element chimney, follow the manufacturer's connection instructions for the relevant chimney type

## CONNECTION BETWEEN BUILT-IN STOVE AND STEEL CHIMNEY

---

Your Scan dealer, or local chimney sweep, can advise you on choosing a make and type of steel chimney. This ensures that the chimney will match your wood-burning stove.

## REQUIREMENTS FOR CHIMNEY

---

**The supplied flue pipe and catalyst are part of the stove and the stove must not be installed without it.**

The chimney must at least have a T400 designation, with G for the soot fire test. We recommend a chimney with a minimum internal diameter of 148 mm and a length of min. 4 metres.

If you opt to connect the built-in stove with an elbow pipe, you should use a curved elbow, as this gives a better draught.

If you connect the stove with a sharp elbow pipe, the cleansing lid must be placed in the vertical part so that the horizontal part can be cleaned through here.

If the chimney is fitted with a smoke extractor, it must be possible to adjust it to a suitable draft.

The stove can be used in a shared flue.

The requirements to the chimney and the flue pipe in terms of safety distances must be met. The chimney shall be proven according to EN 13384-2:2015+A1:2019 depending on the individual situation on site.

- Choosing the wrong length or diameter of chimney could impair functionality
- Always comply exactly with the instructions provided by the chimney supplier

## TRIMS AND DOORS

---

Trims and doors are fitted when the surfaces of the surround have been treated.

## GASKET

---

Gasket 0,75 m is mounted on the inside of the cassette as shown.

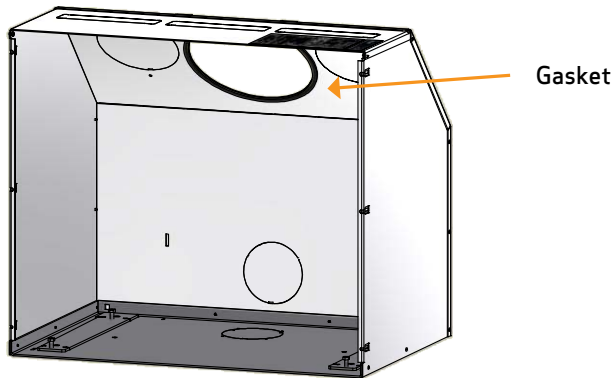

## INTERNAL INSTALLATION IN NON-FLAMMABLE MATERIAL / EXISTING BRICKWORK

---

When building or fitting into structures that do not contain flammable materials, a minimum distance of 10 mm must be maintained between the brickwork and the convection hood. This is to prevent cracks in the brickwork caused by the expansion of the metal while the stove is heating. This construction does not require convection grates except for the convection air produced by the convection box of the insert. However, please note that without convection grates, the effect of the insert will be lower.

## SAFETY DISTANCE

---

European, national and local regulations concerning safety distances for wood-burning stoves and flue pipes must be complied with.

## OPERATING THE DOOR



- 1 Push down the handle and the door will open
- 2 The door should be banged shut, as on a car. Grip the handle (hold in a horizontal position) and bang the door shut



## REMOVE PACKAGING

Check that the built-in stove is not damaged before installing it.

The built-in stove is delivered secured to the pallet. It is recommended that you remove the door and take all loose parts out of the combustion chamber before unscrewing the stove from the pallet; this will facilitate the mounting of the insert.

Dismount the combustion air box. This box is only needed, if the insert is to be connected with external air supply, see page 16.

- 1 To remove the door:

Loosen the pointed screw, remove the screw and the spring and lift off the door

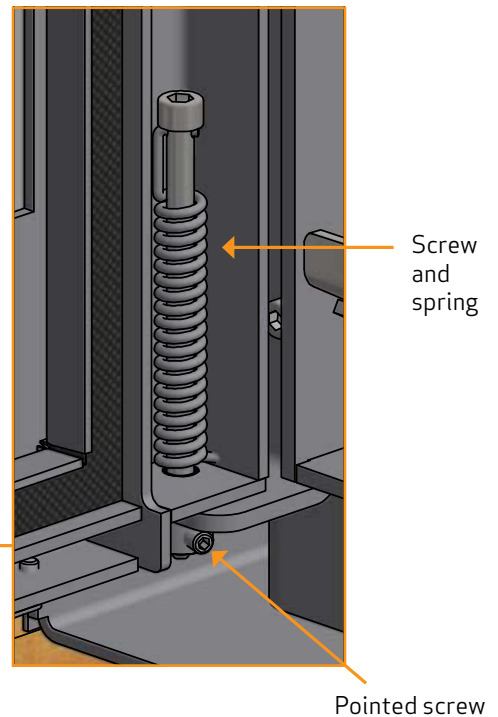
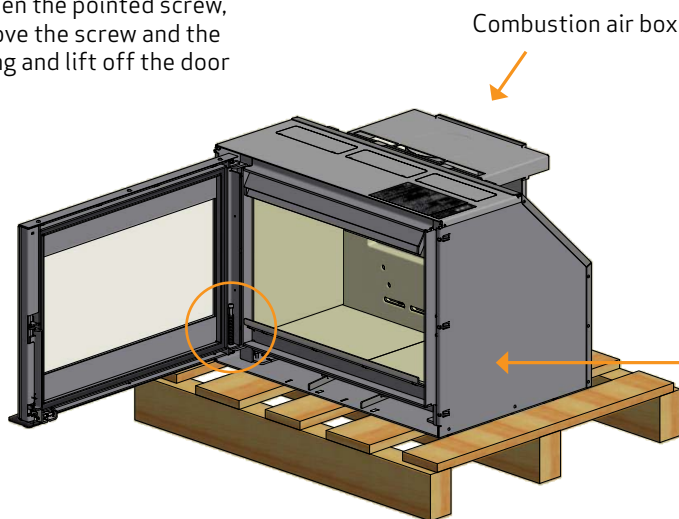

## REMOVE PACKAGING

2

Dismount the connecting piece:

Loosen (not dismount) the flange nuts holding the connecting piece inside the stove. Push the connecting piece in the direction of the arrow and remove it

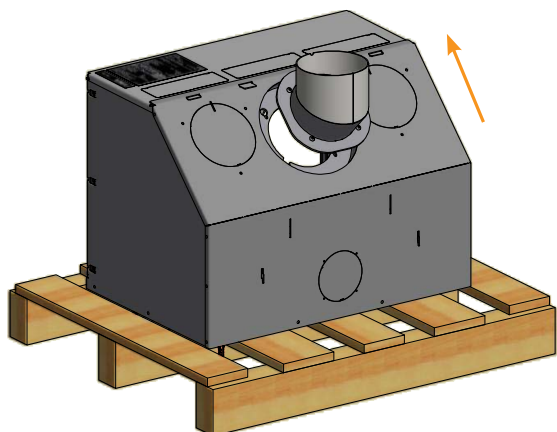

3

Lift the insert free from the grip holes in the front and pull it out of the cassette

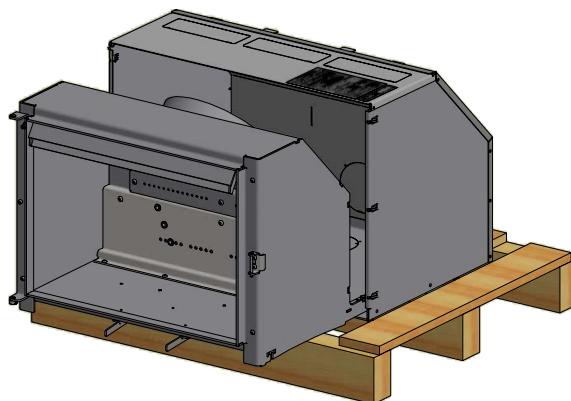

4

Remove the two screws securing the cassette to the pallet

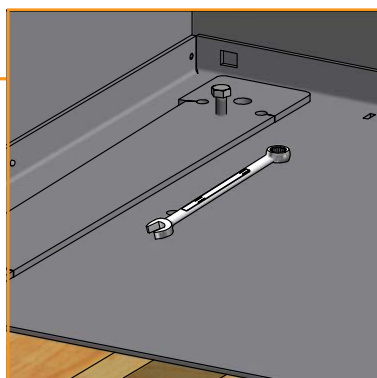
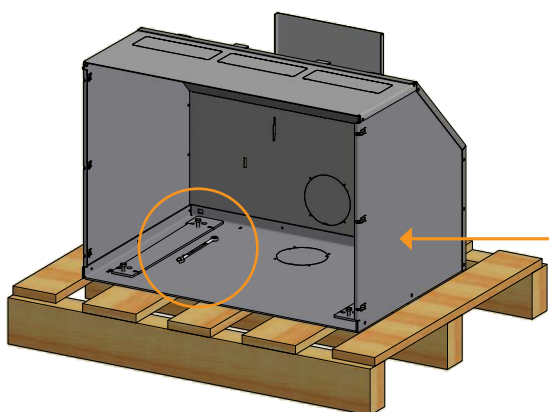

## FITTING THE FLUE CONNECTION PIECE

---

The insert is prepared for a top flue outlet from the factory.

**NOTE: Rear outlet must not be used on this model!**

**NOTE: The insert must be equipped with the supplied 2x1000 mm flue pipe**

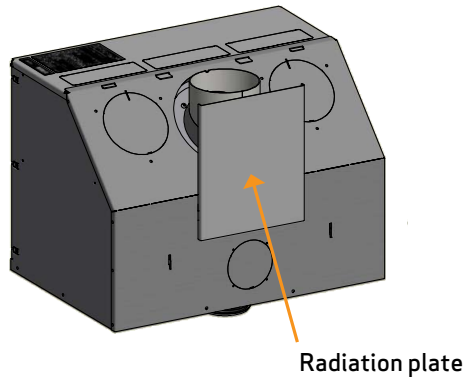

Mount the gasket 3 x 8 mm at the edge of the flange of the connecting piece. Fasten the connecting piece with the flanged nuts

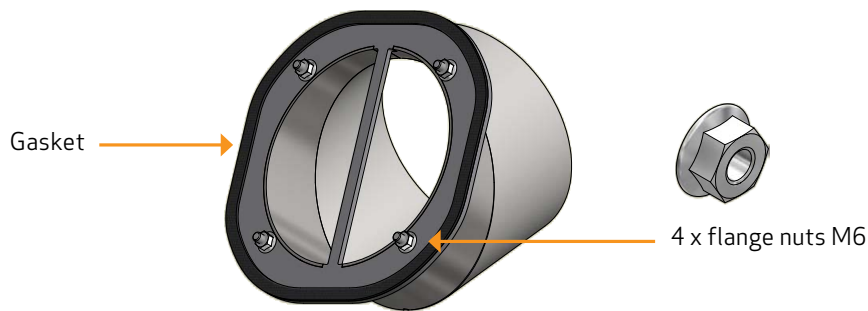

## FRESH AIR INTAKE

---

In a well-insulated house, the air used up by the burning process has to be replaced. This particularly applies to houses with mechanical ventilation. There are different ways of making sure that an air exchange takes place. The most important thing is to ensure that there is a supply of air to the room where the wood stove is located. The external wall vent must be located as close to the wood stove as possible, and you must be able to close it when you are not using the wood stove.

National and local building regulations must be followed with regard to the connection of fresh-air intake.

## CLOSED COMBUSTION SYSTEM

---

You should use the closed combustion system for the wood-burning stove if you live in a newly-built, airtight home. External combustion air is connected through a ventilation pipe via the wall or floor.

We recommend mounting a valve in the ventilation pipe in order to avoid condensate in the stove and the pipe system, which can be closed when the oven is not in use. It can also be an advantage to insulate the ventilation pipe.

Minimum  $\varnothing$  100 mm ventilation pipe, maximum length: 6 metres with a maximum of 3 bends. We recommend smooth steel pipes.

**NOTE:** If the stove has a fresh air connexion or closed combustion, the ventilation pipe must be open, when the stove is in use!

## MOUNTING OF EXTERNAL AIR SUPPLY

To dismantle the cover plates for the  $\varnothing 100$  mm sleeve, use an ordinary screwdriver as shown below. Tilt the screwdriver and loosen the cover plates.

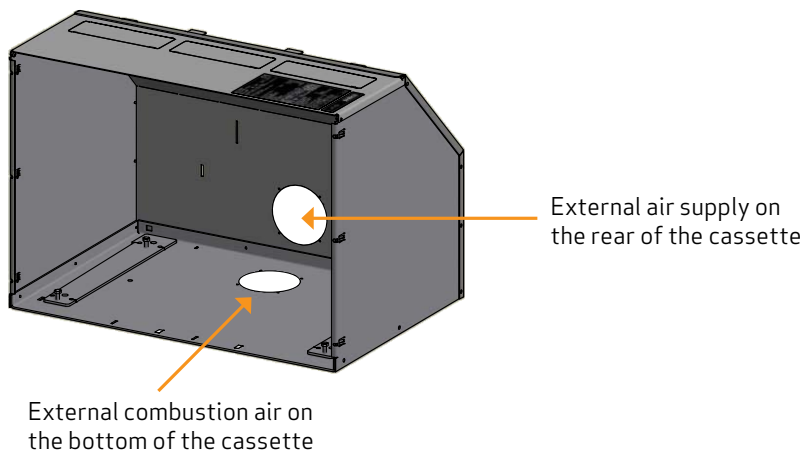

## MOUNTING OF EXTERNAL AIR SUPPLY ON THE REAR OF THE CASSETTE

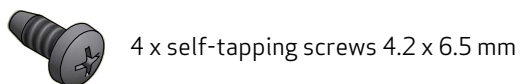
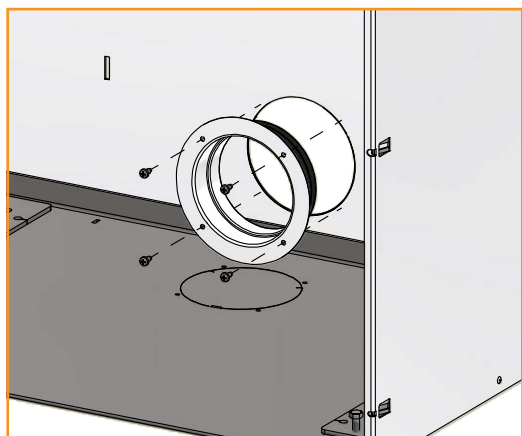

1  
Mount the  $\varnothing 100$  sleeve

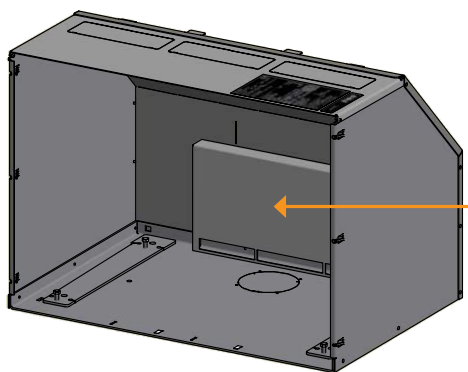

2  
Hitch the combustion air box on the rear plate of the cassette.  
This box must always be mounted when connecting the insert with external air supply.  
**IMPORTANT: Only use for connection with external air supply!**  
Mount the insert in the cassette (see page 22)



## MOUNTING OF EXTERNAL AIR SUPPLY THROUGH THE BOTTOM OF THE CASSETTE

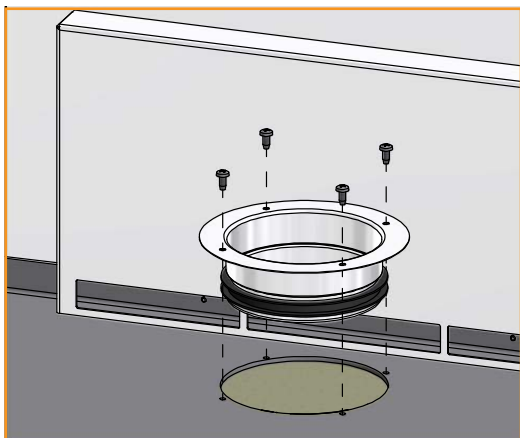

4 x self-tapping screws 4.2 x 6.5 mm

1

Mount the Ø100 sleeve

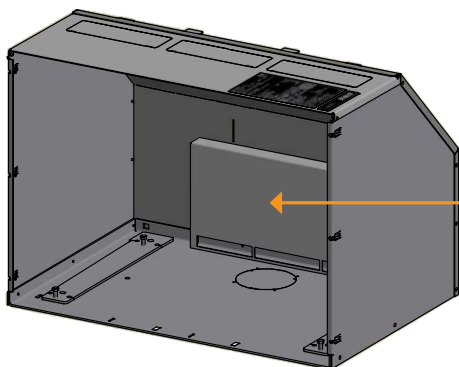

2

Hitch the combustion air box on the rear plate of the cassette.

This box must always be mounted when connecting the insert with external air supply.

**IMPORTANT: Only use for connection with external air supply!**

3

Mount 0.5 m gasket round the flange of the sleeve Ø 100 mm

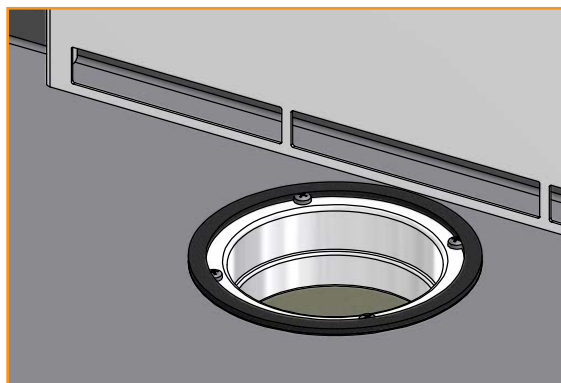

4

Turn the insert over and remove the cover plate at the bottom. Mount the insert in the cassette (see page 22)

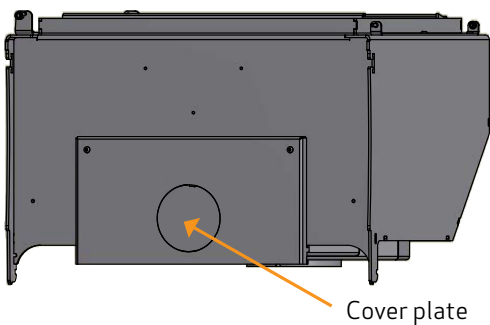

Cover plate

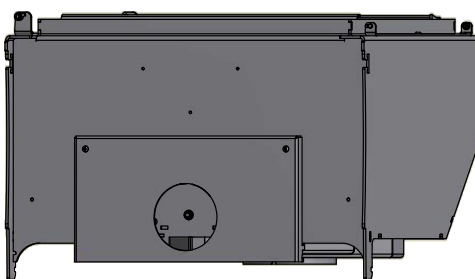

## FITTING WITHOUT THE CONVECTION CONNECTION PIECES

The cover plates in the top plate can be removed in order to reduce the temperature on the wall above the insert. If the insert is built into an existing fireplace the cover plates are not to be removed.

To dismount the cover plates for the convection air, use a slotted screwdriver as illustrated below. Tilt the screwdriver downwards and loosen the cover plate. Fit and tighten the cassette, see "Fitting the cassette".

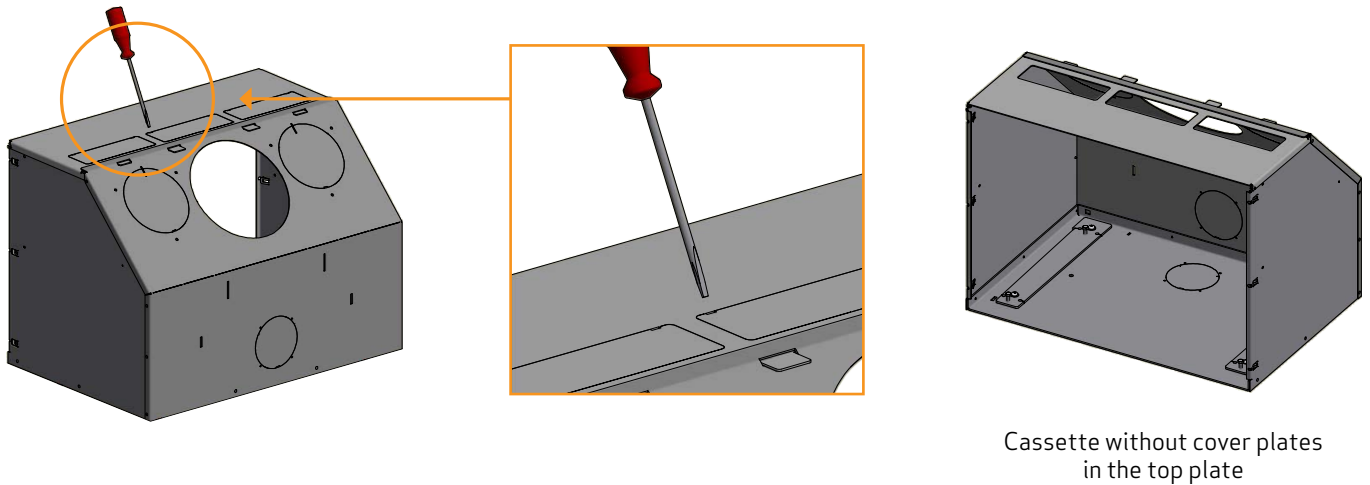

## FITTING THE CONVECTION CONNECTION PIECES (ACCESSORY)

1

Convection connection pieces  $\varnothing 149$  mm

To dismount the cover plates for the convection adaptors, use an slotted screwdriver as shown below. Tilt the screwdriver and loosen the cover plates.

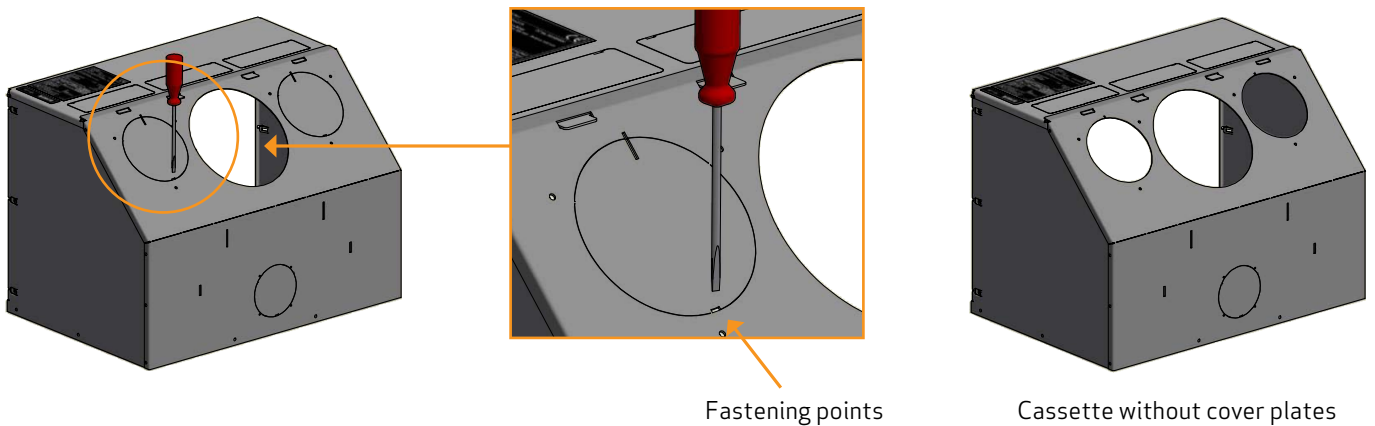

2

Fit and tighten the cassette, see "Fitting the cassette".

When the cassette has been tightened, fit the convection connection pieces. Fit these and tighten them through the hole for the flue connection piece.

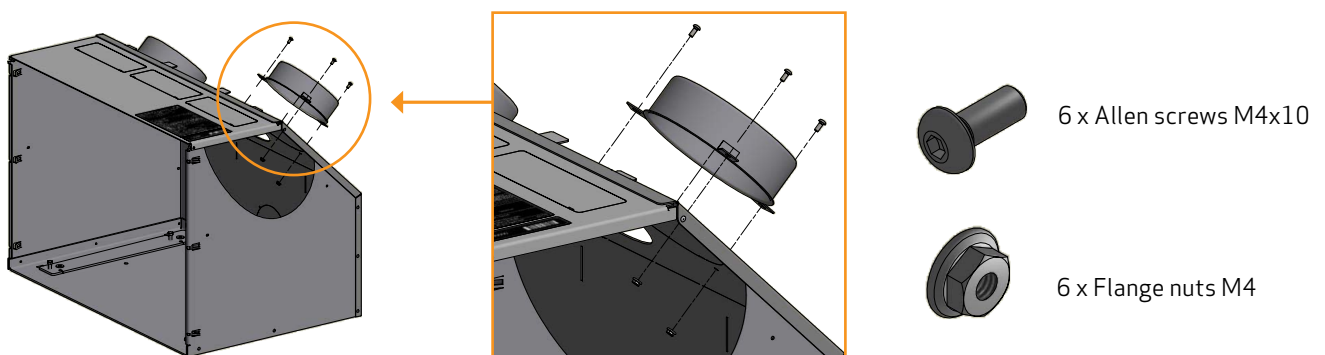

## FITTING THE CASSETTE

1

Place the cassette in the hole/surround

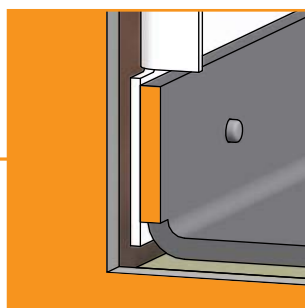
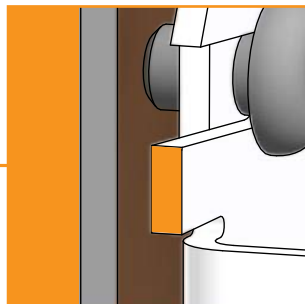
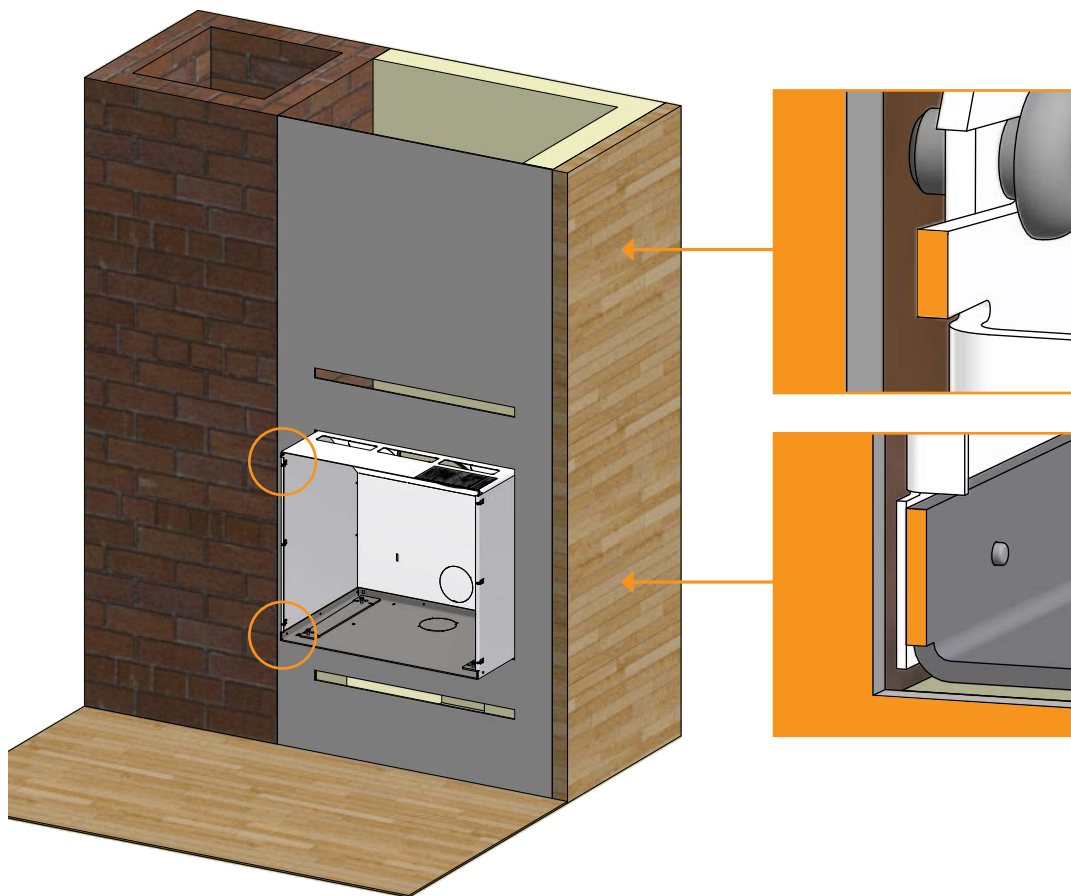

The adjustment points in the four corners of the cassette must be flush with the front of the surround.

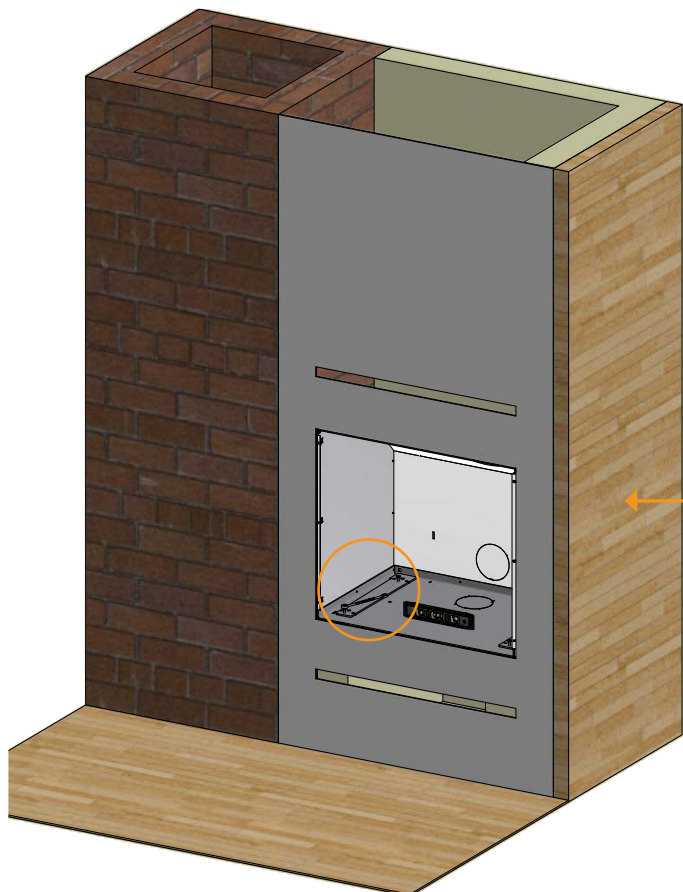

2

To ensure that the cassette is level, you can adjust the adjustment screws with an open-end spanner

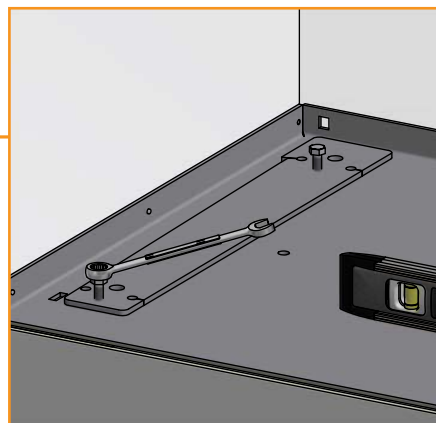

## FITTING THE CASSETTE

3

To secure the cassette, pre-drill the 4 holes with a 10 mm drill bit

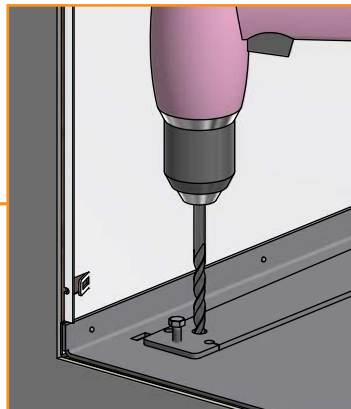
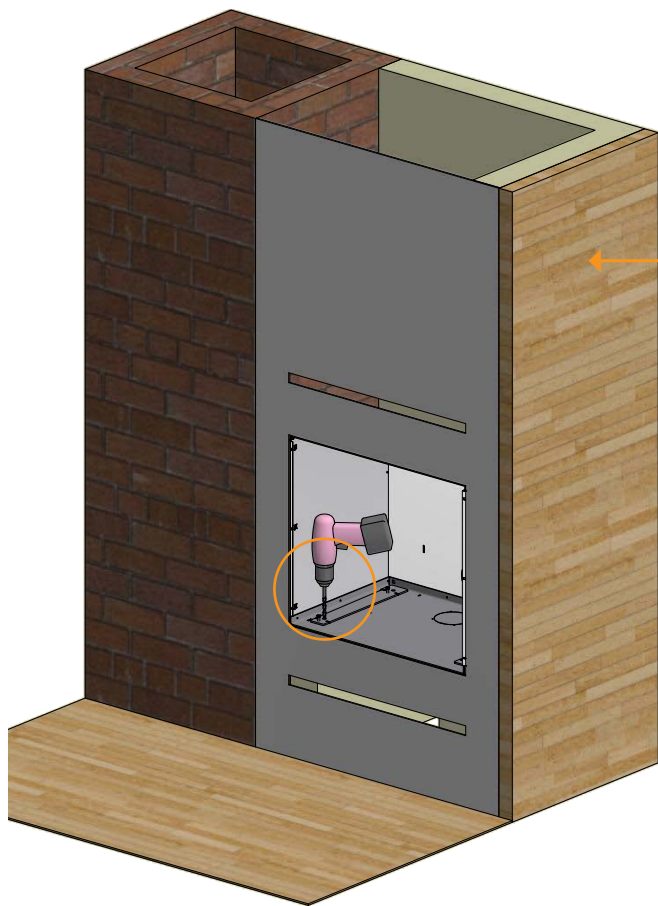

Mount the rawl plugs, screws and discs. Make sure that the cassette is level before fastening it.

In order to fasten the insert, you can use the delivered torx key that you will find in the bag in the combustion chamber

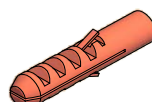
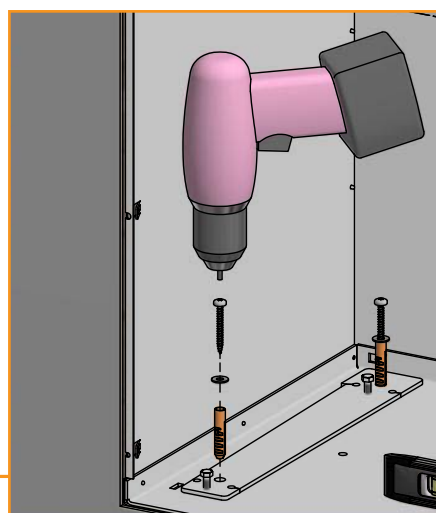
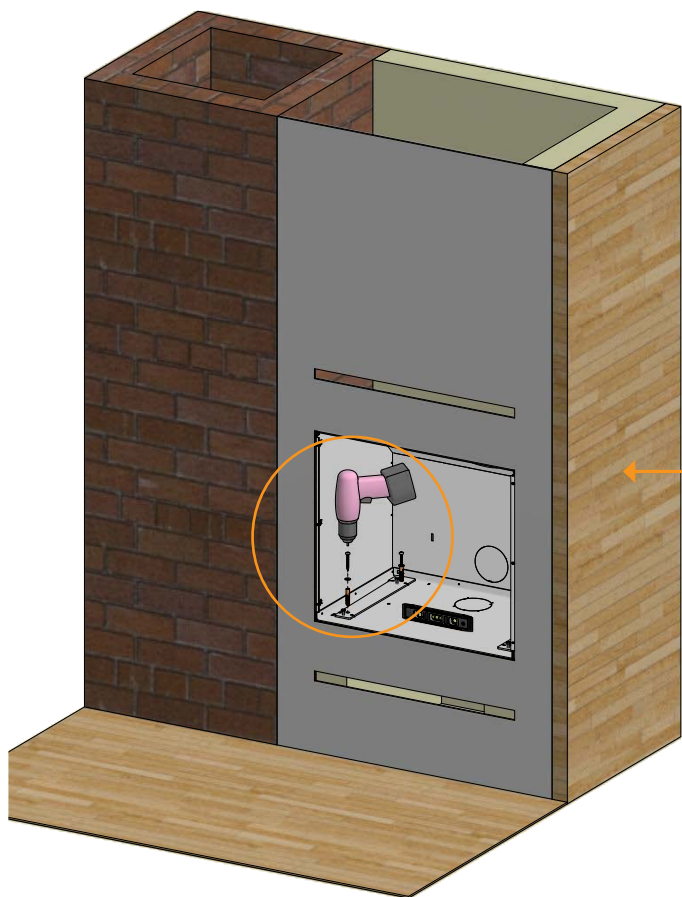

4 x Rawl plugs 10 x 50



4 x Torx screws 6 x 50



4 x Washers  $\text{Ø}6,5 / \text{Ø}16 \times 1,1$

## FITTING THE CASSETTE

5

Loosen the two screws in the cassette

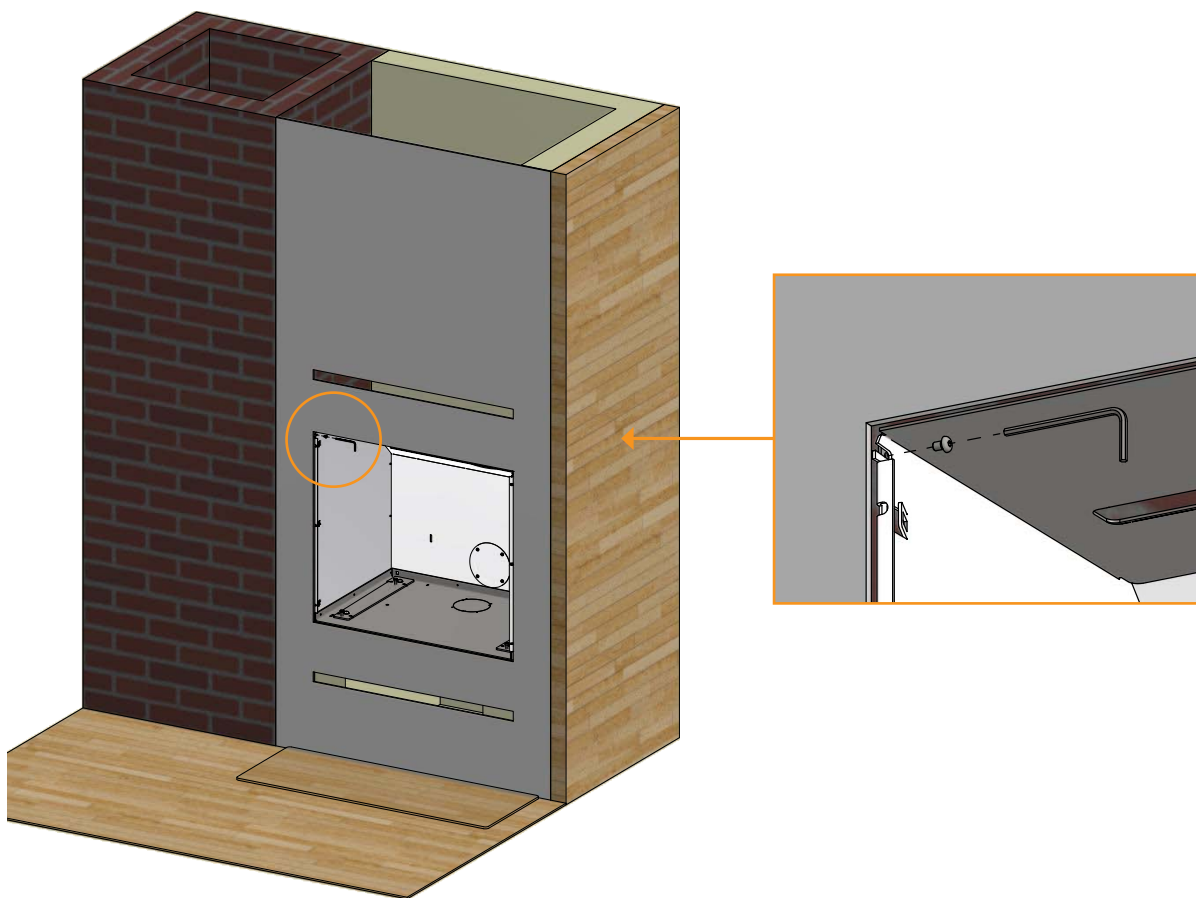

6

Remove the top plate of the cassette

The top plate of the cassette can be dismantled, after the cassette has been fastened. This can help facilitating the mounting of the insert

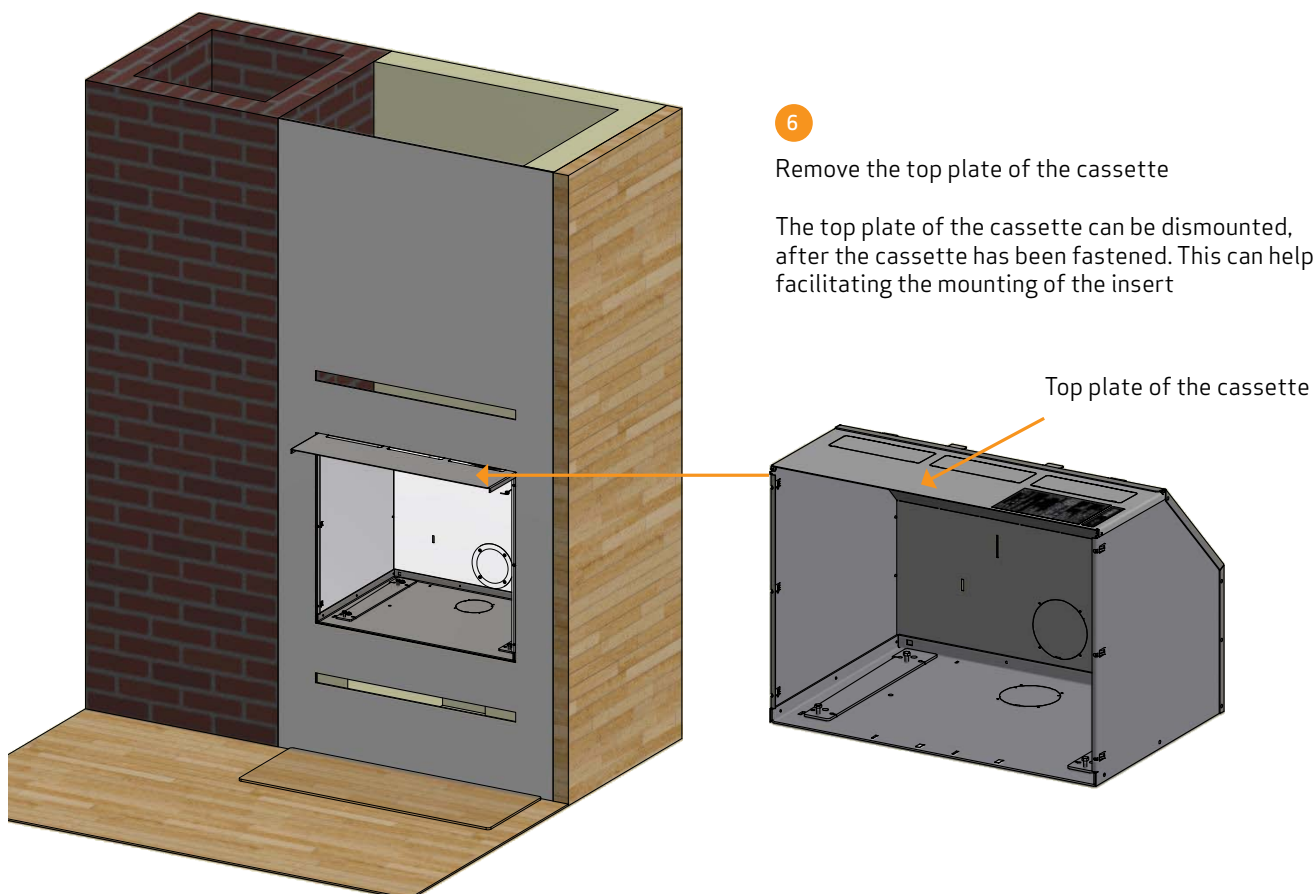

## MOUNT THE INSERT IN THE CASSETTE

1

The stove's pivot pins must fit snugly in the grip holes in the cassette so that the stove is secured tightly



Insert seen from the side

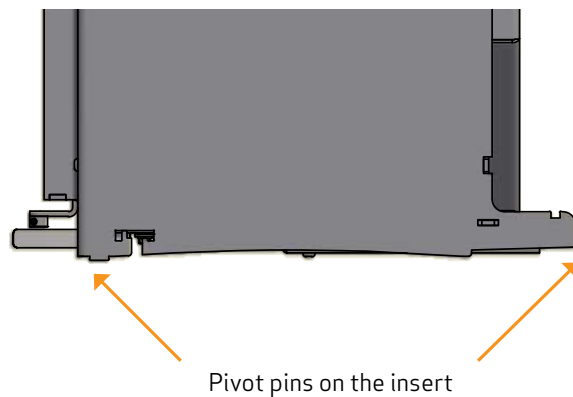

Pivot pins on the insert

Bottom of the cassette

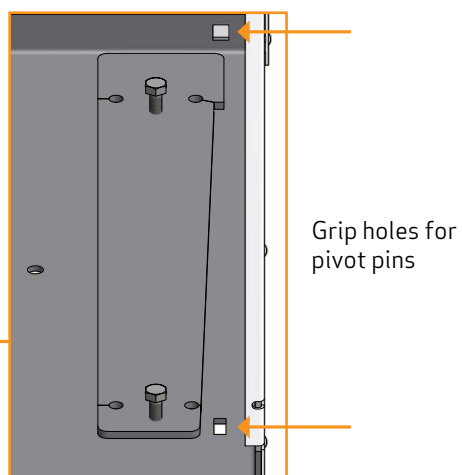
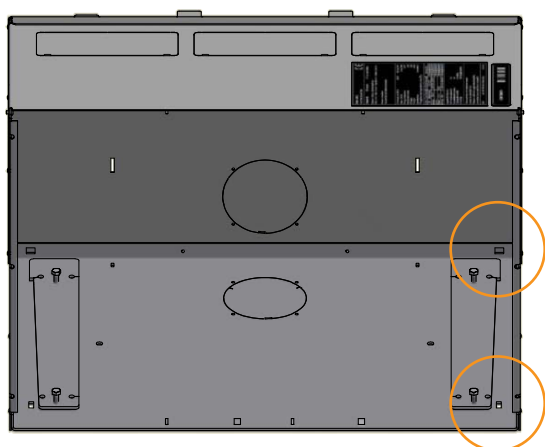

## MOUNT THE INSERT IN THE CASSETTE

2

In order for the insert to be mounted correctly, it must "fall down" into the grip holes of the cassette, so that the insert stands on the bottom of the cassette

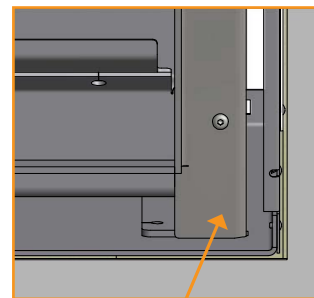
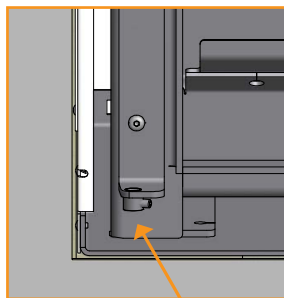
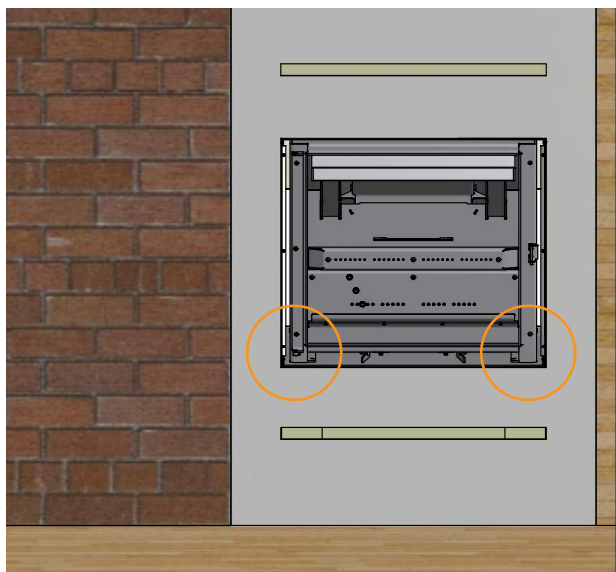

The bottom of the cassette supports the insert

3

Remount the top plate of the cassette and the door

## MOUNTING OF THE TRIM

We recommend that you do not mount the trim, until the insert has been approved by the chimney sweep, as he may demand to see the type plate which is situated on the top plate of the cassette (to dismount the top plate, see page 21).

Mount the guide pins of the trim into the locking devices of the cassette.

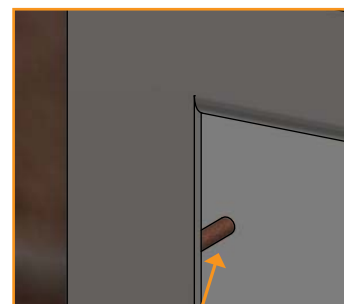
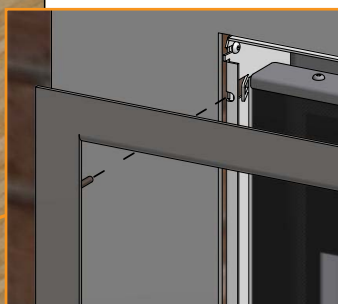
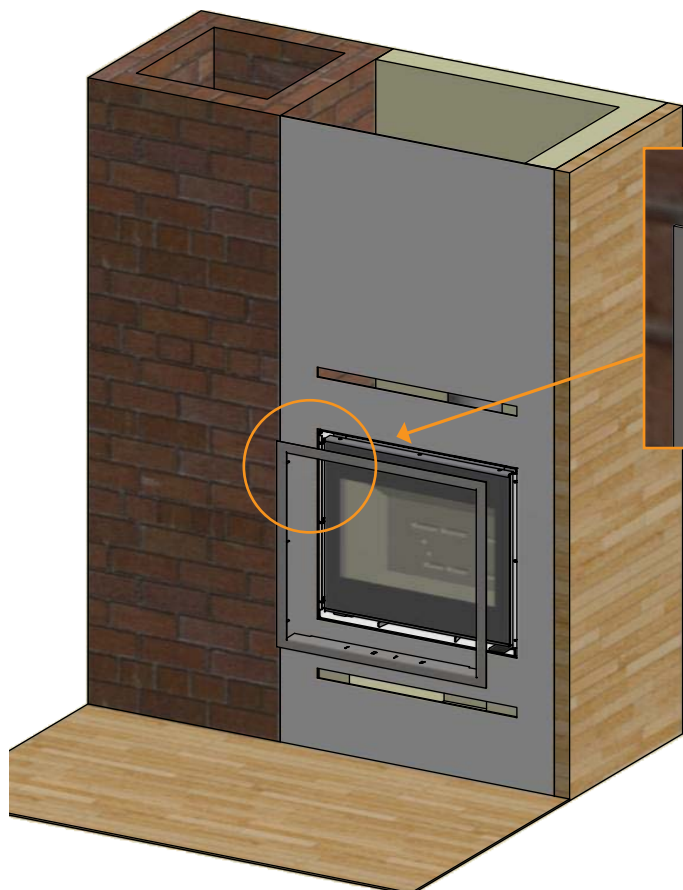

Guide pins

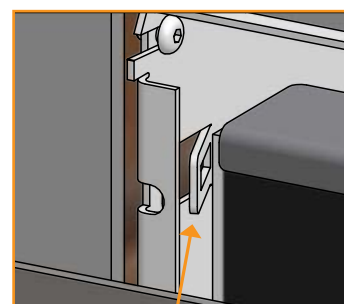

Locking devices

## MOUNTING OF CONVECTION GRATE (ACCESSORY)

(BY BUILDING INTO FLAMMABLE MATERIAL WITH FIRE WALL)

Convection air grids are available as an accessory.

The covering must contain holes for convection air. Convection means that there is an air circulation ensuring that the heat is equally distributed in the room. It is important that the demands concerning convection areas are observed.

- Min. area for ingoing convection air: 350 cm<sup>2</sup>
- Min. area for outgoing convection air: 500 cm<sup>2</sup>

If there is not enough convection air, the covering may be damaged. Do not obstruct the convection holes.

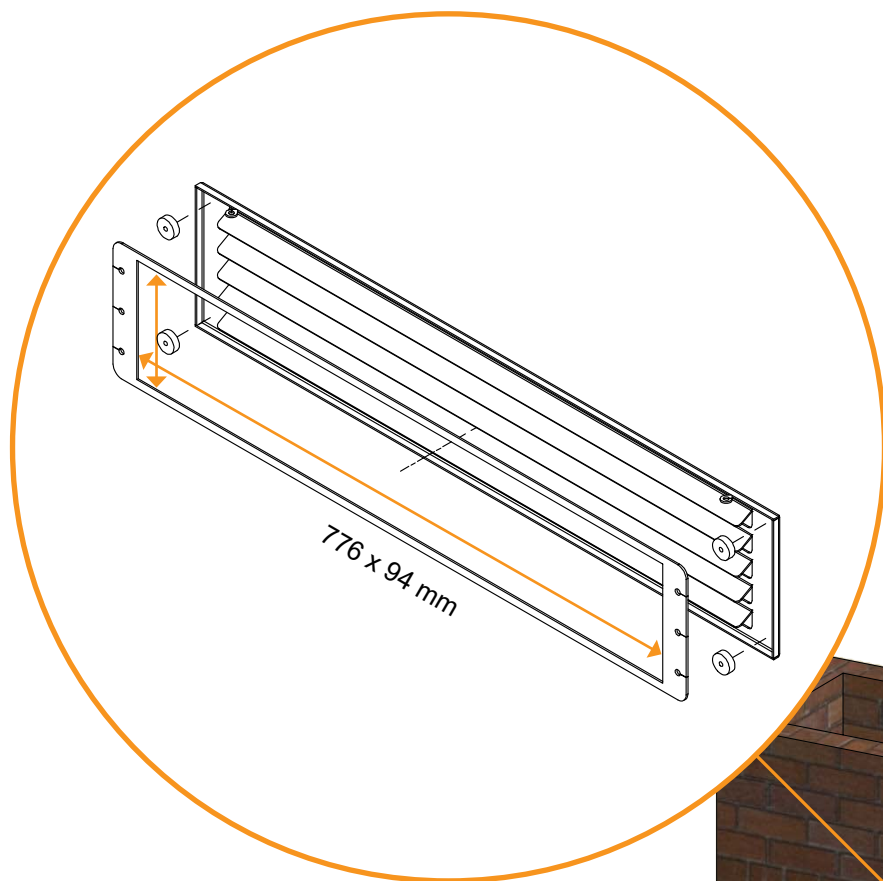

1

Cut a hole in the wall according to the indicated measures

2

Mount the metal frame

3

Place the four magnets on each side of the metal frame and then mount the convection grates on the magnets

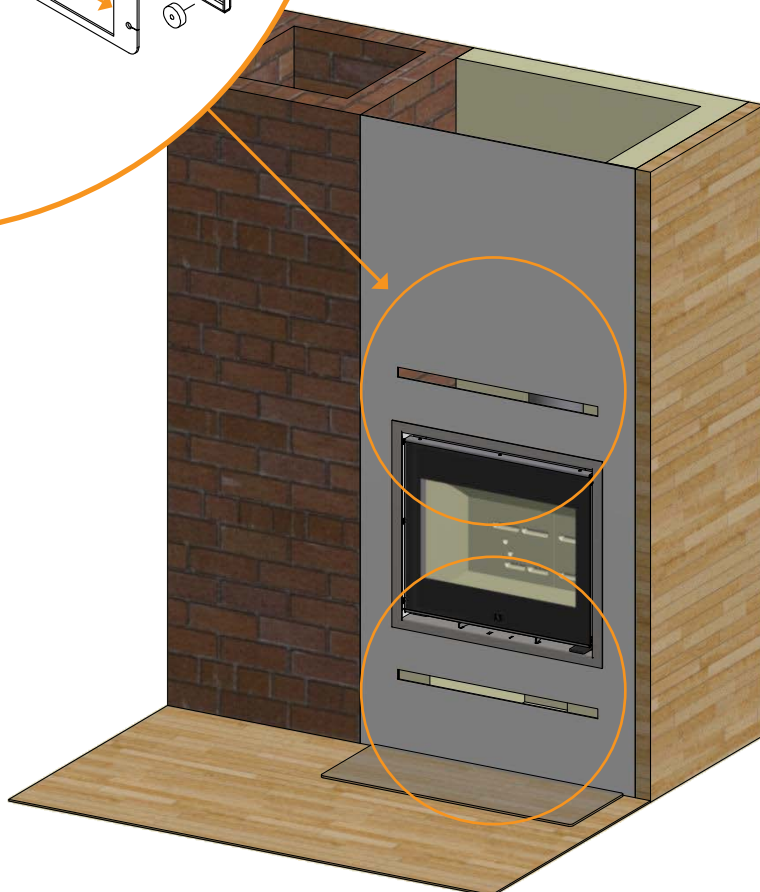



## MOUNTING OF CATALYST

Place the locking shaft in the top of the stove

1

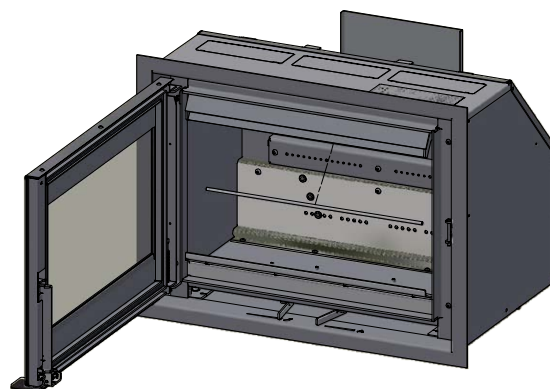
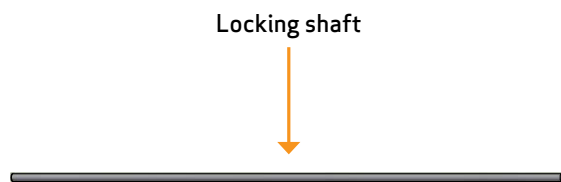

Remove the catalytic converters from the transport packaging and carefully insert them into the box.

2

**IMPORTANT!** The catalyst may only be installed and put into operation by qualified personnel. Please contact your chimney sweep for advice.

Catalytic converter

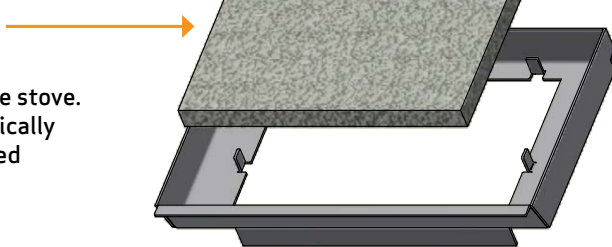

**IMPORTANT!** Wear a glove when handling the stove. In order not to limit the effect of the catalytically active layer, the catalyst must only be handled with gloves, preferably disposable gloves.

Place the catalyst box in the top of the stove. It is important that it is placed correctly

3

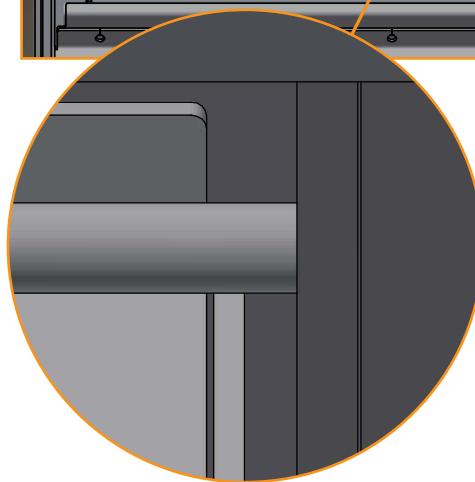
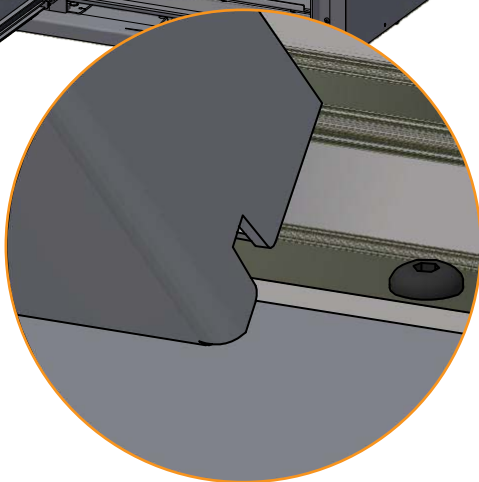
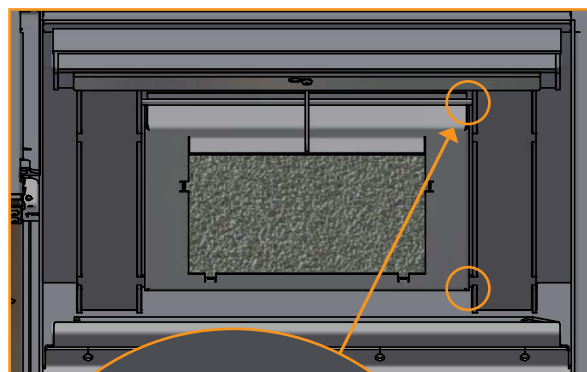
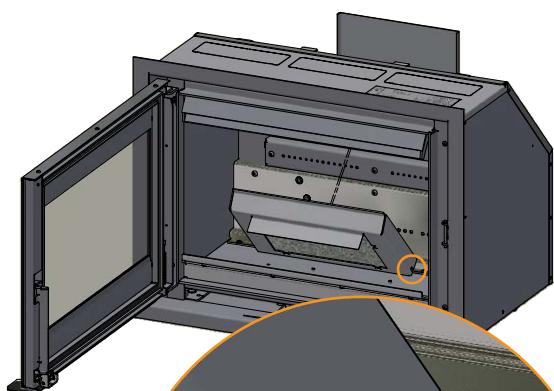

## MOUNTING OF COMBUSTION CHAMBER

Note that the baffle plates are made of porous, ceramic material, and can break. Exercise care when working.

When installing the bottom stones follow instructions 1 and 2 - otherwise proceed to instruction 3

Place the log guard against the front of the insert

1

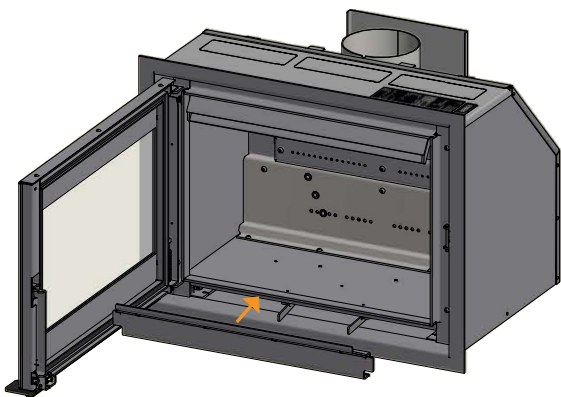

Place the bottom stones with the inclined edge turning to the rear and downwards

2

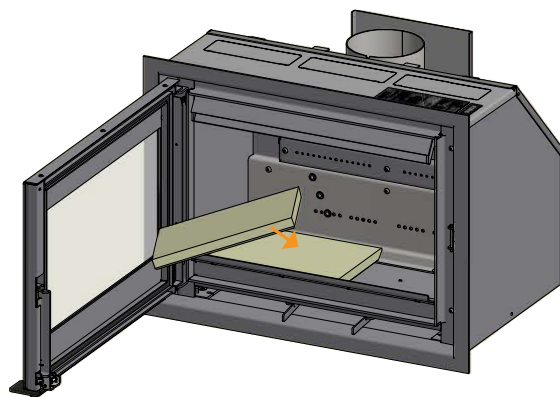

Mount the left rear plate

3

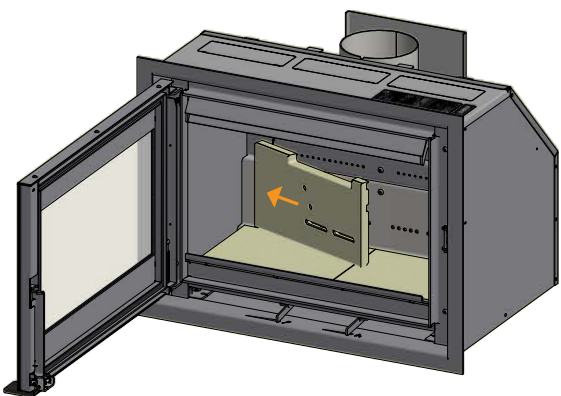

Mount the left burn chamber plate

4

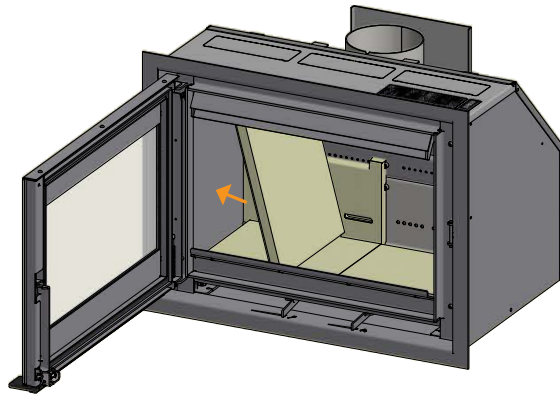

Mount the right rear plate. The rear burn chamber plates must be mounted so that the holes of the plates are placed precisely over the tertiary holes of the insert

5

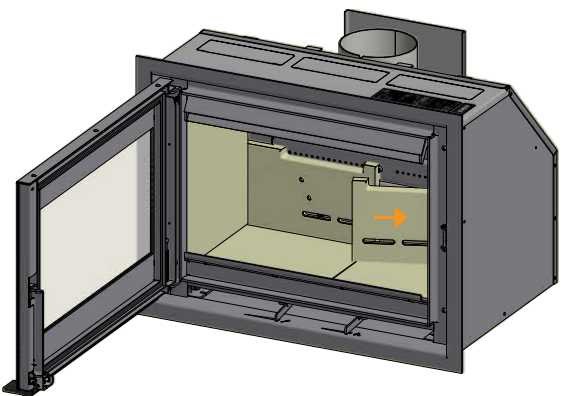

Mount the right burn chamber plate

6

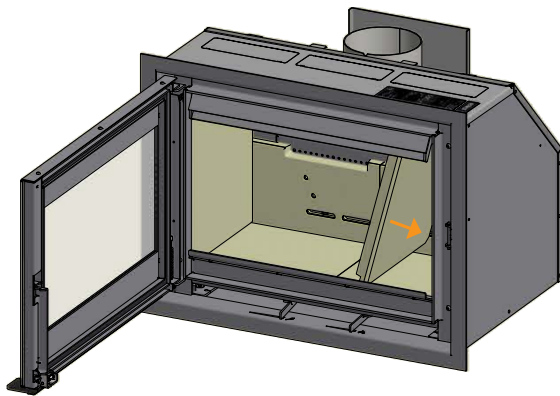

Mount the lower baffle plates. The baffle plates must be supported by the rear plates.  
Mount the pins and put the plates in place

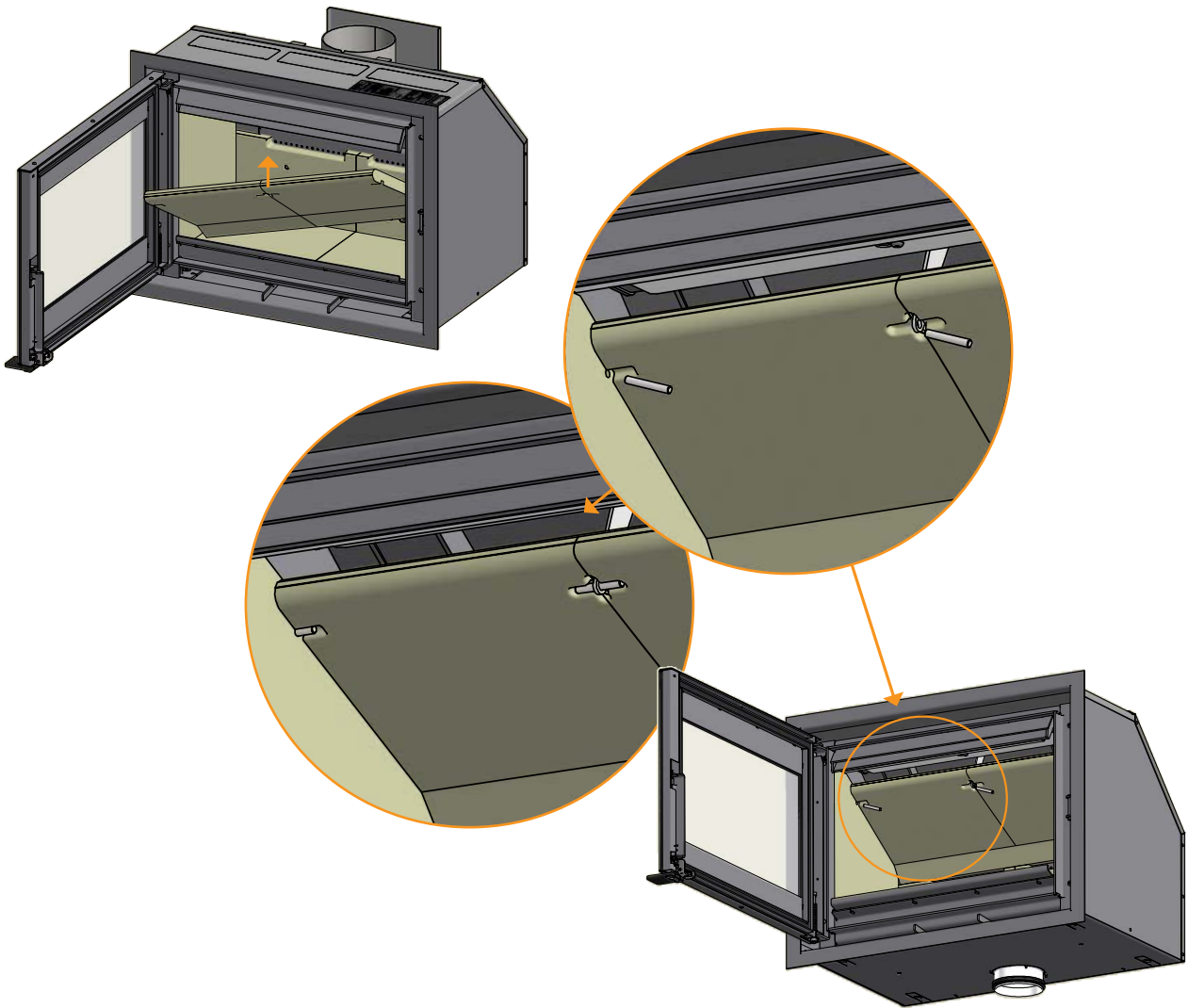

## ADJUSTMENT OF THE DOOR

The door may "hang" a little over time. This can be solved by adjusting the adjustment screw of the door upwards using an 8 mm open-end spanner. The adjustment screw is placed at the top of the hinge as shown below.

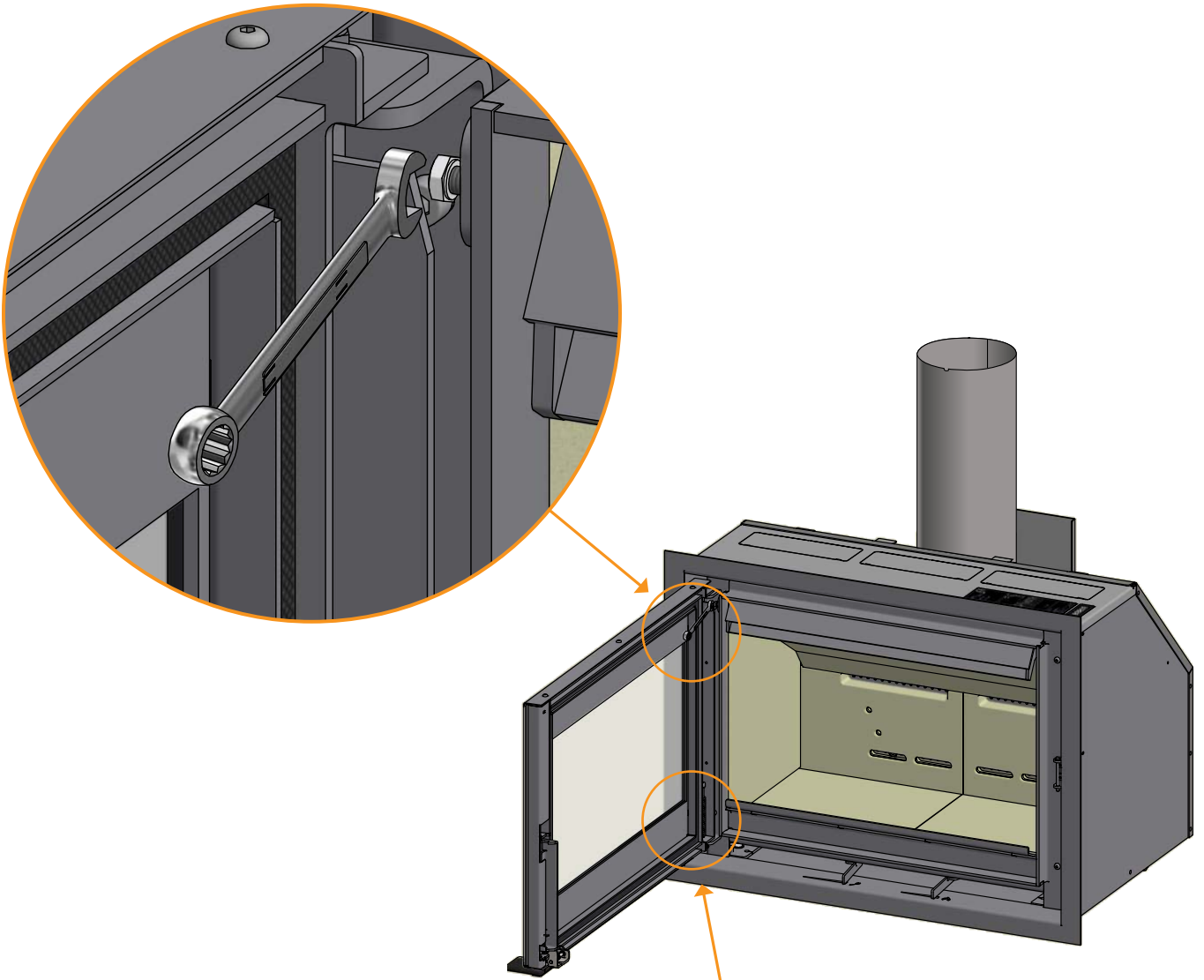

## DOOR (SELF-CLOSING)

The door is delivered without self-closing function (Bauart 1).

If you want a self-closing door, the spring can be tightened by turning the long screw (inside the spring) counter-clockwise using a Allen key (5 mm) and at the same time tightening the pointed screw at the bottom with a Allen key (2.5 mm).

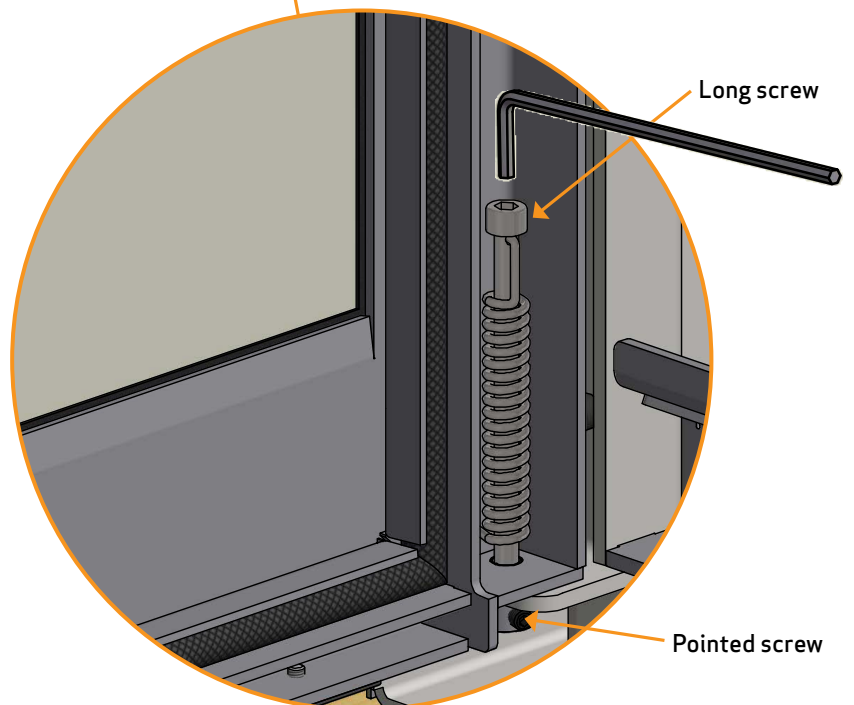

# INSTRUCTIONS FOR USE

## CB-TECHNOLOGY (CLEAN BURN)

The stove is equipped with CB technology. In order to ensure optimal combustion of gases released during the combustion process, air passes through a specially developed system of channels. The heated air is conducted into the combustion chamber through the holes in the rear lining of the combustion chamber and at the baffle plates. This airflow is controlled by the rate of combustion and cannot therefore be regulated.

**NOTE: The wood must never be placed higher than the tertiary holes at the rear of the burn chamber (This does not apply at a cold start).**

## BAFFLE PLATE

The baffle plate is located in the upper part of the combustion chamber. The plate holds back smoke, making sure it stays inside the combustion chamber for a longer time before escaping through the chimney. This reduces the flue gas temperature as the gases have more time to dissipate heat to the stove.

The baffle plate must be removed for sweeping; see "Maintenance". Note that the baffle plate is made of porous, ceramic material, and is liable to break easily. You should therefore handle it with care.

*The baffle plate is subject to wear and tear and not covered by the warranty.*

## PRIMARY AIR

The primary air is used when lighting the stove and must be closed after 10-20 minutes, when the fire has caught well. The primary air can be used continuously when using hard wood.

**Settings for normal load: 0 - 50 %**

## SECONDARY AIR

Secondary air is pre-heated and fed indirectly to the fire. At the same time, the secondary airflow cleans the glass pane to avoid soot build-up. If you over-restrict the secondary airflow, soot can build up on the glass pane. The secondary airflow determines the heat output from your wood stove.

**Settings for normal load: 50 - 100 %**

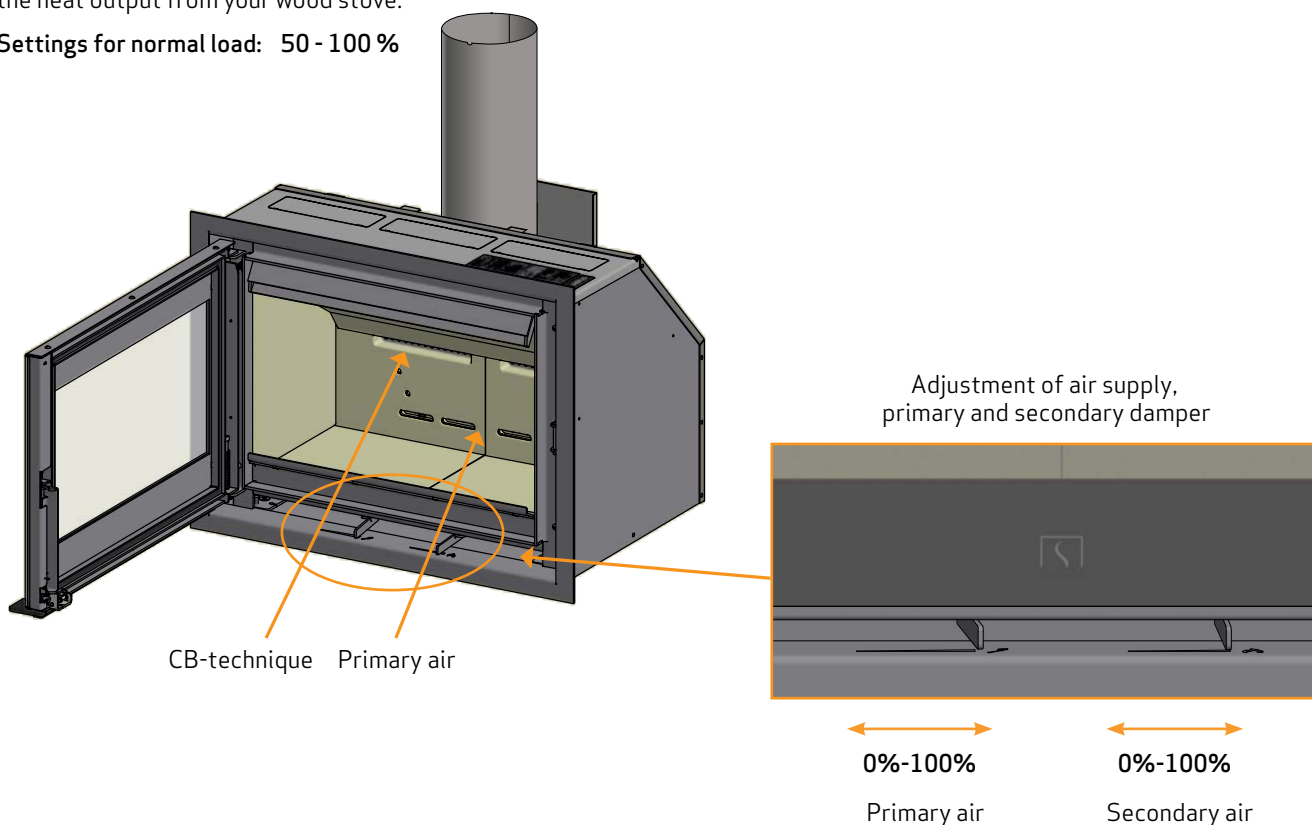

# INSTRUCTIONS FOR HEATING

## ENVIRONMENTALLY-FRIENDLY FIRING

Avoid turning down your woodburning-stove to the point where no flames are visible from the wood, as this leads to poor combustion and low efficiency. The gases released from the wood will not be burnt off due to the low temperature in the combustion chamber. Some of the gases will condense in the stove and flue system as soot, and this could lead to your chimney catching fire at a later point. The residual smoke which exits the chimney will pollute the surrounding area and cause an unpleasant smell.

## LIGHTING

We recommend the use of fire lighters, or similar products, which are available from your Scan dealer. Using fire lighters helps light the wood more quickly and keeps the combustion process clean.

See our video about correct firing on [www.scan-stoves.com](http://www.scan-stoves.com). Please note that this video is only intended as a guide. You should also follow the instructions in the specific manual for your stove model!

**NOTE: Never use liquid lighting fuels!**

The combustion chamber lining may turn black when the fire is lit. It will burn clear again the next time wood is added.

## "TOP DOWN" LIGHTING

"Top down" lighting is a more environmentally friendly way of lighting the fire and helps to keep the glass area as clean as possible.

**Do as follows for a correct "top down" lighting:**

- 4 pieces of wood approx. 25-40 cm long with a weight of approx. 0.6-0.8 kg per piece
- 15 thin pieces of firewood, with a total weight of approx. 0.8-1.0 kg
- 3-4 fire lighters

- 1 Place the pieces of wood, firewood and fire lighters in the combustion chamber as shown below
- 2 Set the primary and secondary air controls to maximum in the lighting phase. If the fire is too strong, you may throttle down the primary air damper (at the left)

**NOTE: The wood must never be placed higher than the tertiary holes at the rear of the burn chamber (This does not apply at a cold start).**



Place the fire lighters between the upper sticks

## CONTINUOUS OPERATION

---

It is important to obtain as high a temperature as possible in the combustion chamber. This results in best possible use of the stove and fuel, as well as achieving clean combustion. In this way you will avoid build-up of soot on the combustion chamber lining and glass pane. During operation, you should not see any smoke; just a movement in the air that indicates combustion is in progress.

- After completing the lighting phase, you should have a good layer of embers in the stove; you can then start operation of it properly
- Add two pieces of wood at a time: they should be about 1 kg in weight and about 25-40 cm long

**NOTE: The wood must catch fire quickly. This is why we recommend setting the primary air flow fully open. Operating the stove at too low a temperature and with too little primary air can lead to gases igniting, which can damage the stove.**

- When adding wood, always open the glass door carefully to prevent smoke escaping. Keep the door closed during the whole combustion phase
- Never add wood, while the fire is burning nicely

**At the EN 16510-test the stove was fired as shown on the picture:**

With three pieces of birch each 250 mm – 15-16 % wood humidity  
- with a total weight of 1.71 kg.

Primary air damper 15 % open – secondary air damper 90 % open.

Refuelling interval: 46 min

Criterion for the end of test cycle: 4,7-5,2 % CO<sup>2</sup>



Must be placed close together

## WARNING ABOUT OVER-FIRING

---

If the stove is continuously fired with larger amounts of wood than recommended and/or receives too much air, this can cause a heavy heat development liable to damage both stove and the surrounding walls. We therefore recommend that you always observe the max. recommended amount of fuel (See under "Technical Data").

## USING THE STOVE IN VARIOUS WEATHER CONDITIONS

---

The way the wind affects the chimney can have a big impact on how your stove reacts under various wind loads; you may need to adjust the airflow to achieve good combustion. Fitting a damper in the flue pipe may also help, as it will allow you to regulate the draught under changing wind loads.

Fog and mist can also have a big impact on chimney draught; you may need to use other settings for the combustion air to achieve good combustion.

## FIRING IN THE SPRING OR AUTUMN

---

In the spring/autumn transition period, where there is less need for heating, we recommend you light the stove "top down" once, perhaps adding just two pieces of wood to ensure that the combustion chamber lining burns clean again.

## GENERAL NOTES

---

**PLEASE NOTE! Parts of the wood-burning stove, especially the outer surfaces, become hot during use. Due care should be exercised.**

- Wear a glove when handling the stove
- Never empty ashes into a flammable container. Ashes can contain glowing embers long after you finish operating the stove
- Keep the combustion chamber closed except during ignition, refuelling and removal of residue material to prevent fume spillage
- Keep the air intake and output holes free from any accidental blockage while the stove is in use
- When the stove is not in use you can close the dampers to avoid a draught through the stove
- If the stove has not been used for some time, you should check the flue passageways for potential blockages before relighting
- We advise you strongly not to use the stove over night. The stove is not suited for this purpose

**NOTE: Never place flammable material in the radiation zone of the stove!**

## THE FUNCTION OF THE CHIMNEY

---

The chimney is the wood-burning stove's motor; its performance determines how well your stove will work. The draught in the chimney creates negative pressure in the wood-burning stove. The negative pressure draws the smoke out of the stove and takes in air through the combustion air damper to fuel the combustion process. Combustion air is also used for the air wash system that keeps the window clear of soot.

The draught in the chimney is created by the difference in temperature inside and outside the chimney. The higher temperature difference, the better draught. This is why it is important that the chimney reaches operating temperature before you reduce the damper settings to restrict combustion in the stove (a brickwork chimney will take longer to reach operating temperature than a steel chimney). It is very important that the operating temperature is reached as quickly as possible on days when the draught in the chimney is poor due to unfavorable wind and weather conditions. You need to get a few flames going as quickly as possible. Chop the wood extra thin; use an extra fire lighter etc.

- After longer periods without use, you must check the chimney flue for blockages
- You can connect several units to the same chimney. You should however first check the relevant regulations in this respect

## CHIMNEY FIRE

---

In the event of a chimney fire, keep the stove door and dampers on the stove closed. In an emergency, call the fire service.

- We recommend that you get a chimney sweep to check the chimney before using the stove again



# HANDLING OF THE FUEL

## SELECTING WOOD/FUEL

You can use any type of wood as fuel. However harder woods, such as beech or ash, are generally better for heating, as they burn more evenly and create less ash. Other woods, such as maple, birch and spruce, are excellent alternatives.

## PREPARATION

The best fuel is obtained where the tree has been felled and the wood sawn and split before May 1st. Remember to cut the wood to match the size of the combustion chamber. We recommend a diameter of 6-10 cm. The length should be about 6 cm shorter than that of the combustion chamber to leave enough space for air to circulate. If the diameter of the wood is greater than the above, it should be split down its length. Wood that has been split dries faster.

## STORING

You need to store the sawn and split wood in a dry place for 1-2 years before it will be dry enough to burn. Wood dries faster if you stack it in an airy place. Before using it, it is a good idea to store the wood for a few days at room temperature. Remember that wood absorbs moisture from the air during autumn and winter.

## MOISTURE

To avoid problematic impact on the environment and to ensure optimum operating economy, the wood should be perfectly dry before it can be used as fuel. If you use wood that is too damp, most of the heat it produces will be used up in evaporating the water. The stove will accordingly not increase in temperature, nor emit heat to the room as a result. This is obviously poor economy, and it will cause soot build-up on the glass pane, in the stove and in the chimney. Operation using moist wood also pollutes the environment.

- Maximum wood moisture content should not exceed 20%. A moisture content of 15-18% will deliver best efficiency
- An easy way of checking wood moisture content is to knock the ends of the two pieces of wood together. If the wood is moist, the sound will be slightly muffled
- It is a good idea to take the wood into the house a day before it is to be used

## USE OF THE FOLLOWING AS FUEL IS ILLEGAL

**NOTE:** It is absolutely prohibited to fire with painted, pressure impregnated or glued wood, or sea driftwood.

**NOTE:** Never use gasoline, gasoline-type lantern fuel, kerosene, charcoal lighter fluid, ethyl alcohol or similar liquids to start or "reignite" a fire in the stove. Keep all such liquids well away from the stove while it is in use.

**NOTE:** Nor should you ever burn chipboard, plastics, waste or treated paper. These contain substances that are hazardous to human health, to the environment, your stove, and your chimney.

In short - make sure you only use proper wood.

## CALORIFIC VALUE OF THE WOOD

The various woods have different calorific values. In other words, for certain species of wood, you will need to use a greater quantity to achieve the same heating performance. This Instruction Manual assumes that you will be using beech, which has a very high calorific value and is also the easiest wood to get hold on. If you use oak or beech as fuel, you need to bear in mind that these wood types have a greater calorific value than for example birch. To avoid any risk of damage to the stove, you should therefore make sure to use less fuel in these cases.

Wood types	kg Drywood/m <sup>3</sup>	Compared to beech
Hornbeam	640	110%
Beech/Oak	580	100%
Ash	570	98%
Maple	540	93%
Birch	510	88%
Pine	480	83%
Fir	390	67%
Poplar	380	65%

# MAINTAINANCE

## SWEEPING THE CHIMNEY AND CLEANING THE STOVE

---

Follow national and local regulations for sweeping the chimney. We recommend having the stove cleaned regularly by a chimney sweep.

Before cleaning the stove and sweeping the flue pipe and chimney, we recommend removing the baffle plates. (See section "Removal of baffle plates and combustion lining")

**NOTE: All service and reparation must be done, when the stove is cold.**

## CHECKING THE STOVE

---

Scan A/S recommends that you check your stove thoroughly after sweeping/cleaning. Check all visible surfaces for cracks. Check that all joints are tight and that the gaskets are correctly seated. Worn or deformed gaskets should be replaced.

## SERVICING

---

We recommend that the stove is thoroughly serviced at least every two years by a qualified fitter. Remember only to use original spare parts.

**The service should include the following:**

- Lubricate hinges using copper grease
- Check the gaskets. Replace any that are broken or have turned hard
- Check the combustion chamber lining
- Check heat-insulating materials
- Check the locking device
- Check the catalyst. Clean or replace it

## COMBUSTION CHAMBER LINING

---

Slight cracks can appear in the combustion chamber lining due to moisture or sudden heating/cooling. These cracks have no influence on the output or lifetime of your stove. However, if the lining starts to crumble and fall out, you must replace it.  
*The combustion chamber lining is not covered by the warranty.*

## CATALYST

---

Check catalyst for breakage and clogging. This wears out with use and must be cleaned or replaced when necessary.

*Catalyst is not covered by the warranty.*

## GASKETS

---

All wood-burning stoves have seals made of ceramic material fitted to the stove, the door and/or the glass. These seals are subject to wear and tear and must be replaced when necessary.

*Gaskets are not covered by the warranty.*

## PAINTED SURFACES

---

Clean your wood-burning stove by wiping it down with a dry, lint-free cloth.

If the paint finish gets damaged, you can purchase repair paint in spray form from your Scan dealer. As slight differences in colour shade are possible, we recommend you spray a larger area to achieve a natural blend. For best results, apply repair spray when the stove is warm, but it should preferably not be scalding hot.

**NOTE: Make sure to air the room thoroughly after applying spray paint.**

## CLEANING THE GLASS

Our wood-burning stoves are designed to prevent serious soot build-up on the glass. The best way to achieve this is to make sure you have a good supply of combustion air. It is also very important that the wood is dry and the chimney correctly dimensioned.

Even if you operate the stove in accordance with our instructions, a slight film of soot may still accumulate on the glass. You can easily remove this film by wiping the glass down with a dry cloth and then with a cloth dampened with glass cleaner.

- Please note that the glass cleaner is not to get into contact with the gaskets, as this can discolour the glass permanently
- The glass cleaner must not come into contact with the painted surfaces, as these can be damaged

## REMOVAL OF BAFFLE PLATES AND COMBUSTION CHAMBER LINING

Be very careful when removing the baffle plate from the stove.

- Lift up the lower baffle plate, remove the pins and take out the baffle plate
- Lift the upper baffle plate to the back of the combustion chamber and remove it
- Lift the burn chamber side plates free from the bottom stones and take them out. Please note that the sides support the rear plates and that these may fall over, when the sides are taken out
- Take out the rear plates

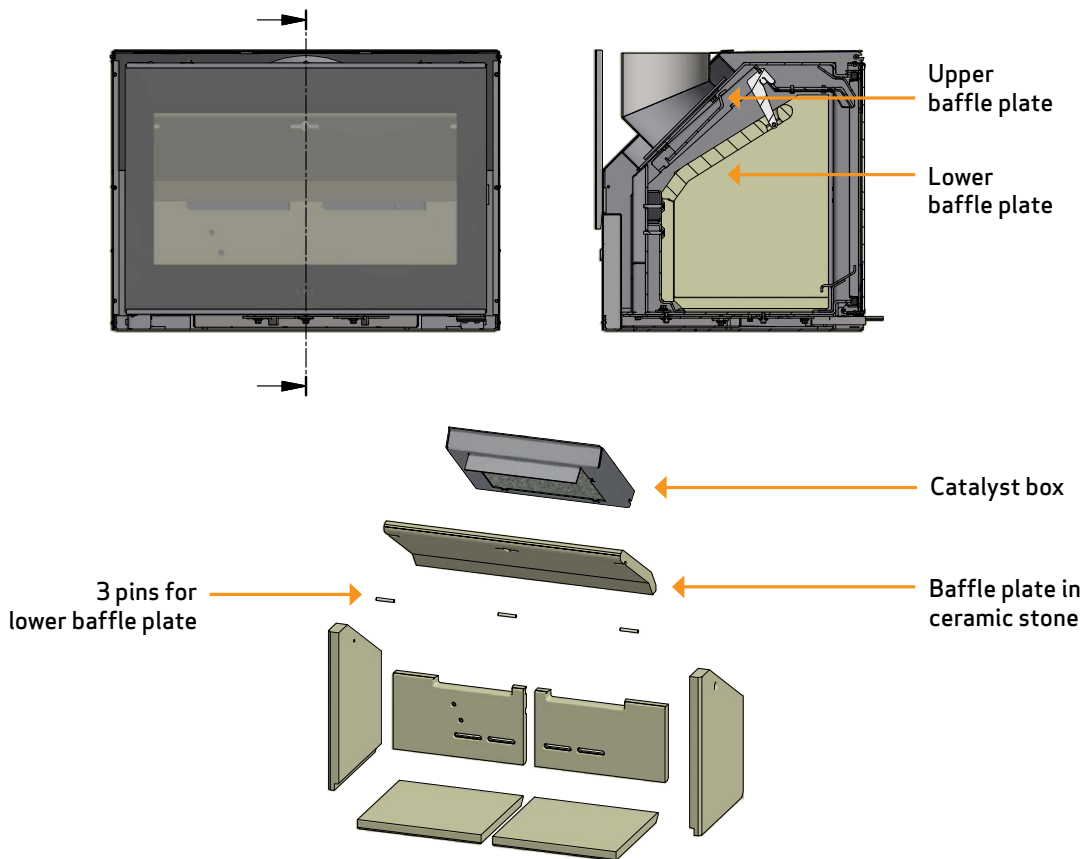

## DISPOSAL OF STOVE PARTS

Steel/cast iron	Send for recycling
Glass	Dispose of as ceramic waste
Combustion chamber lining	Ceramic stone and chamotte are not recyclable. Dispose of as waste
Baffle plate	Ceramic stone and chamotte are not recyclable. Dispose of as waste
Gaskets	Dispose of as waste
Catalyst	Return the used catalyst to Scan via the dealer

# TROUBLESHOOTING

## SMOKE ESCAPING

---

- Damp wood
- Chimney is not properly dimensioned for the stove
- Is the chimney the right height for its surroundings?
- At rear outlet, check that the flue pipe does not obstruct the chimney draught
- Chimney not drawing properly
- Check if the smoke gas pipe/chimney are blocked
- Vacuum in room
- The door is opened before the embers have burned down sufficiently

## WOOD BURNING TOO QUICKLY

---

- The air valves are set incorrectly
- Inferior firewood (waste wood, pallets etc.)
- The baffle plates is incorrectly mounted or missing
- Chimney too large

## SOOT BUILD-UP ON GLASS

---

- Incorrect secondary airflow setting
- Damp wood
- Inferior firewood (waste wood, pallets etc.)
- Vacuum in room
- Excessive primary air
- Wood pieces too large on lighting
- Chimney not drawing sufficiently

## WHITE SHADOW ON THE INSIDE OF THE GLASS

---

- Over-firing (See "Instructions for heating")
- Vacuum in the room
- Too much primary air

## EXCESSIVE SOOT BUILD-UP IN CHIMNEY

---

- Poor burning (more air required)
- Damp wood

## THE SURFACE OF THE BUILT-IN STOVE IS TURNING GREY

---

- Overheating (see instructions for heating)

## POOR HEATING PERFORMANCE OF BUILT-IN STOVE

---

- Damp wood
- Inferior wood quality with low fuel value
- Not enough wood
- Baffle plates are not fitted correctly

## SMELL AND SOUND OF THE BUILT-IN STOVE

---

- The lacquer on the built-in stove hardens, when you use the built-in stove for the first time; this can cause an odour. Open a window or a door for ventilation and make sure that the built-in stove is heated up sufficiently to avoid odours later.
- When heating up and cooling down, the built-in stove may make some clicking noises. These are due to the huge temperature differences to which the material is exposed and do not indicate any product defects.

# WARRANTY

All wood-fired Scan products are made of high-quality materials and subject to strict quality controls before leaving the factory. We give a warranty of 5 years on manufacturing errors or defects.

You must quote your stove's product registration number when you contact us or your authorized Scan dealer with a warranty claim.

The warranty covers all parts which in the opinion of Scan A/S require repair or replacement due to manufacturing or construction error

The warranty applies to the original purchaser of the product only, and is not transferable (except on prior sale).

The warranty covers only damage caused by manufacturing or construction errors.

## THE FOLLOWING PARTS ARE NOT COVERED BY THE WARRANTY

---

- Wear and tear parts, such as the catalyst, combustion chamber liners, baffle plates, riddling grate, glass, and seals (except for defects which were present on delivery)
- Defects caused by external chemical and physical influences during transportation, storage and assembly, or at a later time.
- Soot build-up caused by poor chimney draught, damp wood, or improper use
- Costs of additional heating in connection with a repair
- Transport costs
- Costs for setting up, removing the wood stove

## THIS WARRANTY IS VOID

---

- In case of incorrect installation (the installer is responsible for observing and complying with legal requirements and local bylaws, along with this Instructions manual for the wood-burning stove and accessories)
- In case of improper use, and/or use of prohibited fuels, non-original spares (see this instructions manual)
- If the product registration number of the stove has been removed or damaged
- In case of repairs that do not comply with our instructions or instructions by an authorized Scan dealer
- In case of any manipulation of the original state of this Scan product or its accessories. Any unauthorized modification of the stove may not be carried out
- This warranty is only valid in the country to which this Scan product was originally supplied

Always use original replacement parts, or parts recommended by the manufacturer.





Product registration number

Quote this number at all enquiries